

On the use of SHIM6 for Mobility Support in IMS Networks

John Ronan, Sasitharan Balasubramaniam
Telecommunications Software and Systems Group
Waterford Institute of Technology, Carriganore
Waterford, Ireland

{jronan, sasib}@tssg.org

Adnan K Kiani, Wenbing Yao
School of Engineering and Design
Brunel University
West London, United Kingdom

{Adnan.Kiani, Wenbing.Yao}@brunel.ac.uk

ABSTRACT

The future of network communications is moving towards deployment of an all-IP core network. This has given rise to many devices hitting the market equipped with multiple network interfaces. However, in order to really benefit from such a heterogeneous network environment, applications must experience minimum disruption as they roam from one network to another, which requires seamless mobility support. Although, some mobility proposals have emerged (Mobile IPv6, and its extensions), none of them give satisfactory performance in terms of handover between different networks. In addition, they require infrastructural changes to the network and give poor performance in case of a failure. In this paper, we propose a mechanism to support mobility through a multi homing SHIM6 layer. The results show that our proposed mechanism outperforms Route Optimized Mobile IPv6.

Keywords

Mobility, MIPv6, SHIM6, IMS, SIP.

1. INTRODUCTION

Future 4G networks will witness users performing seamless mobility between multiple unified heterogeneous networks while minimizing application disruptions. This vision has been recognized and has driven much research towards supporting seamless mobility. However, current protocols for mobility have drawbacks that prevent seamless mobility. One of these drawbacks is the requirement for infrastructure changes to support mobility, which is not attractive to communication network operators. The need for mobility support has increased in the last number of years, especially with the proliferation of mobile devices with multiple network interfaces, as well as an increase in the number of access network technologies (e.g. WiFi). Future 4G networks will witness evolution towards an all-IP based structure, where the core networks will be IP-based supporting multiple access networks. This will necessitate mobile operators to pursue mobility support for their customers, where devices will be able to stream multimedia content with minimal disruption during handovers. A key challenge to such support is to provide all IP-based inter-networking between the different network technologies, in particular with the focus of maintaining session

Permission to make digital or hard copies of all or part of this work for personal or classroom use is granted without fee provided that copies are not made or distributed for profit or commercial advantage and that copies bear this notice and the full citation on the first page. To copy otherwise, to republish, to post on servers or to redistribute to lists, requires prior specific permission and/or a fee.

TRIDENTCOM 2008, 17th – 20th Mar 2008, Innsbruck, Austria.
Copyright © 2011 – 2012 ICST ISBN 978-963-9799-24-0
DOI 10.4108/tridentcom.2008.3226

negotiations during handover operations. In [4], Xu et al investigated the use of Session Initiation Protocol (SIP) to perform session negotiation during handover, supporting IP multimedia subsystem (IMS).

Although the authors of [4] have investigated IMS support for service convergence they have focused heavily on providing uniform service experience, and not on seamless roaming and handoff. Since seamless handover [1], has been investigated extensively through the use of Mobile IP, this solution requires infrastructure changes (e.g. addition of Home Agents). Apart from infrastructure changes, the solution is also not robust to failures: failures in the Home Agent could lead to failure of mobility support. In this paper, we propose a new concept towards supporting mobility, in particular for IPv6. The solution proposed in this paper is to support mobility through a multi-homing solution in IPv6 known as SHIM6 [5]. In particular, we have focused on seamless support for the IMS based systems inter-networking architecture, with minimal architectural changes

This paper is organized as follows. §2 presents the related work on seamless handover. §3 presents our overall architecture for seamless mobility in IMS based systems, while §4 presents the SHIM6 description. §5 presents the integrated SHIM6 for IMS inter-networking architecture handover operations. §6 presents the results of simulated test-bed, §7 initial results from a early test-bed realization and lastly §8 presents the conclusion to the paper.

2. Related Work

Chakravorty et al [1] proposed a vertical handover mechanism between WLAN and GPRS, and GPRS and WLAN by employing Mobile IPv6 (MIPv6) protocol. The MIPv6 protocol supports location management using Binding Updates (BU), which allow packets of a new stream to be directly transmitted from the correspondent node to the mobile node's new location. However, the protocol requires changes to router software to support MIPv6 protocol and other support devices such as Home Agents (and, indeed multiple home agents for reliability). Balasubramaniam et al [2] proposed a context-aware fast vertical handover mechanism, where handover decisions are based on centralized Adaptability Manager located within each network. The context-aware handover solution developed at DoCoMO Labs [3] aims to perform handover decision to the right access point by not only considering signal strengths but also context information. Although the device does evaluate context information for handover decision, this context information is only used to select the appropriate access points and not for handover decision purposes.

3. Architecture

The architecture of our proposed solution is presented in Fig. 1. It can be seen that, the IMS supports the multimedia services for the IP based networks (in this case, UMTS and WiFi). The inter-network architecture is composed of two main components: the signaling network, and the data transport network. In the IMS network, a key component is the Call Session Control Function (CSCF). The sole responsibility of the CSCF is to setup and establish sessions. There are two types of CSCF: the Proxy CSCF (P-CSCF) is the gateway point to the IMS subsystem, while the Serving CSCF (S-CSCF) is in charge of the user registration and management of the session. The IMS systems are composed of a SIP registry, where users are able to register to indicate the network they are currently attached to. SIP also supports mobility [7], whereby the user can register with the SIP registrar in the event that they obtain a new IP address when their point of attachment changes (this function is located in the S-CSCF).

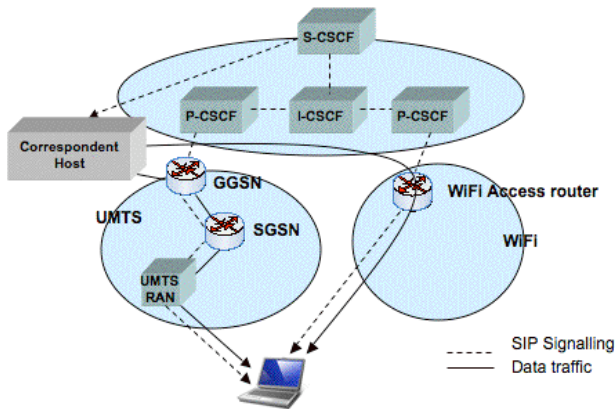

Figure 1. Architecture for IMS based network integrated with mobility support.

4. SHIM6

As described earlier, SHIM6 [5] is a multi-homing solution in IPv6. It is a Network layer approach that provides the split of locator/identifier of an IP address, so that multi-homing can be provided for IPv6 with Transport-layer survivability. In essence, it specifies a layer 3 “shim” approach and protocol for providing locator agility below the transport protocols, so that multi-homing can be provided for IPv6 with failover and load spreading properties. This is without assuming that a multi-homed site will have a provider-independent IPv6 address prefix that is announced in the global IPv6 routing table. The hosts in a site which have multiple provider-allocated IPv6 address prefixes, can use the SHIM6 protocol to set up state, called ULID-pair context with peer hosts, so that this state can later be used to failover to a different locator pair, should the original pair stop working. A SHIM6 endpoint can use a constant IP address as an Upper Layer Identifier (ULID) for an association. For each Upper Layer Protocol (ULP) connection, SHIM6 establishes a context state by using four signaling messages: I1, R1, I2 and R2, so the SHIM6 context, associating a ULID pair with a set of locators for endpoints, performs as a per-host header address mapping function. This functionality is indicated in Figure 2.

This concept, when applied to this scenario, is an improvement over the traditional Mobile IPv6 mobility support system, for a number of reasons.

From the figure, we can see that, on Node A, the ULP selects the initial locator pair (e.g. L1(A) and L1(B)) being the ULID pair, (which both avoids introducing a new identifier name space and avoids modification of the application). The SHIM6 context provides a set of associations between endpoint identifier pairs (e.g. L1(A) and L1(B)) and locator sets (e.g. L2(A) and L3(B)).

In the case of a path failure, when packets are passed from the ULP to the IP Layer, the endpoint identifiers of the ULP are mapped to a current pair of locators. The reverse mapping is applied to incoming packets: the incoming locator pair is stripped off the packet, and the packet header is rewritten with the mapped endpoint identifier pair. Packets are then passed to the ULP

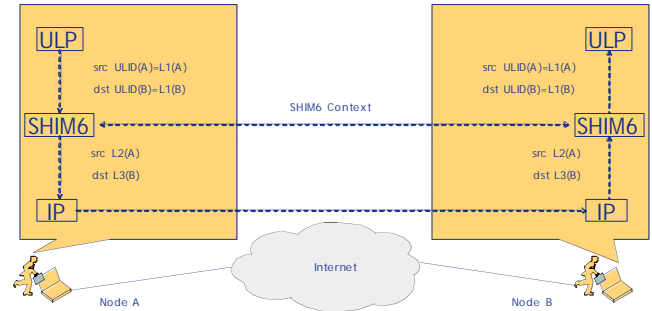

Figure 2. SHIM6 Architecture.

5. Handover Operation

5.1 IMS with Mobile IPv6

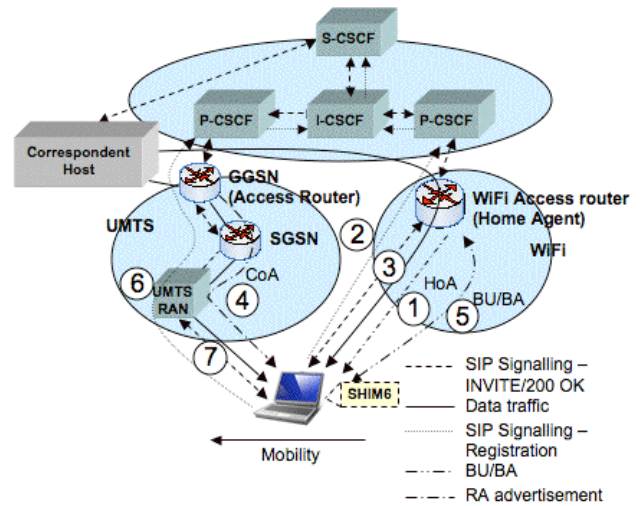

Figure 3. Mobile IPv6 Support for IMS architecture interaction process.

Our comparison of the IMS for Mobile IP is based on the work of Faccin et al [7]. The architecture is presented in Fig. 3, while the scenario interaction is presented in Fig. 4. The scenario description of our handover is based on a user attached to their home network (WiFi), and migrating to a GPRS/UMTS network. The operation is a two step process. Initially, the mobile device detects the presence in the respective network, before continuing the session. The sequence operation shown in Fig. 4, shows that

initially the mobile device receives a home address (HoA) from the home network and registers itself with the Home Agent (1) and uses this address to register with the SIP registry in the S-CSCF (2). Upon registration, the S-CSCF is responsible to invoke the correspondent host to begin transmission to the mobile node. The operation for the SIP session includes SIP registration, approval reply "SIP 200 OK", session invite "INVITE", and reply for session invite "200 OK", before the streaming is performed (3). In the handover process, a two step process is performed which includes handover detection and handover execution. The handover detection we have considered for our Mobile IPv6 handover is based on receiving Router Advertisement (RA) over a specific threshold from the visiting access router (V-AR) (4) [8]. In [8], two mechanisms were proposed for handover detection: (i) the MN soliciting router advertisement when entering the new network, and (ii) the MN detecting router advertisement that are constantly transmitted from the network the node is about to migrate to.

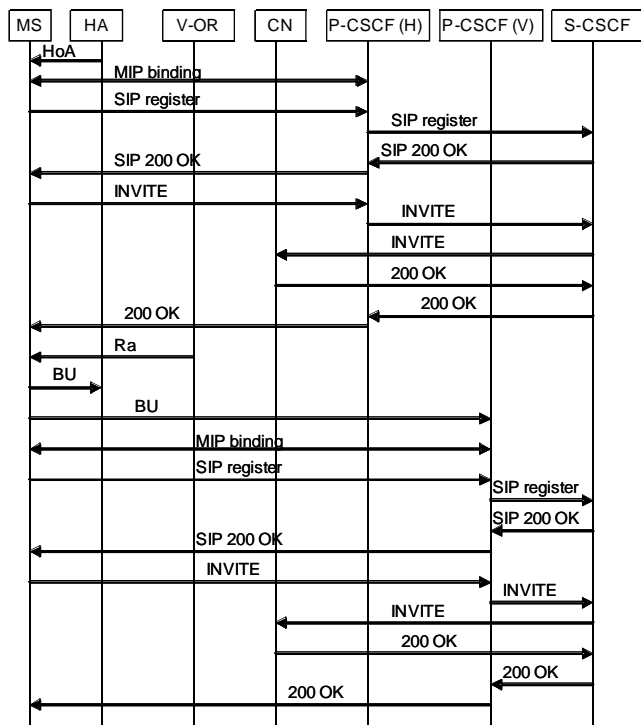

Figure 4. Mobile IPv6 support for IMS sequence diagram.

When the mobile device receives the router advertisement from the visiting network (V-OR), the mobile device sends a Binding Update (BU) to the home agent as well as to the P-CSCF (V) of the visiting network (5) (6). Upon successful registration, the invite is transmitted from the P-CSCF (V) to the S-CSCF, where the S-CSCF will transmit a new invitation to the corresponding node (CN), which will transmit the new stream to the new network (7). Unlike conventional Mobile IPv6, which would submit a BU directly to the CN, the MN will only perform this operation through the P-CSCF(V), and view this as the CN. The P-CSCF will then re-register with the S-CSCF (at the same time notifying the registry of the new IP address of the mobile node). During this process, a disruption will occur as the mobile node re-registers with the new network, and at the same time re-registers with the IMS network. In [7], the authors propose mechanisms that will allow parallel operation of registration, where the SIP

operation and MN registration in the new network can be performed at the same time. At the same time, the old stream could be transmitted through the Home Agent and sent to the new network (triangular routing), during the handover operation to minimize packet loss.

5.2 IMS with SHIM6

Since our aim is to create a new mechanism for mobility support through SHIM6, while at the same time addressing provisioning of services for IP-based networks, we have integrated the SIP protocol using IMS with the SHIM6 protocol. The architecture of this solution is presented in Fig. 5

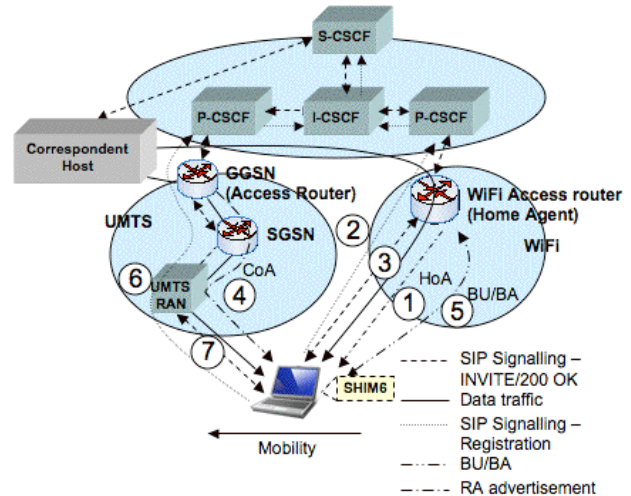

Figure 5. SHIM6 support for IMS architecture interaction process

The added advantage of using SHIM6 is that multihoming is supported. Therefore, simultaneous addresses are supported in parallel. This leads to a different sequence of interactions. Based on Fig. 5 and 6, initially the MN can register two addresses with the P-CSCF (H) as well as the P-CSCF (V), for the HoA and CoA received from the two networks respectively (operation 1 and 2). While the MN is performing the SIP registration (3), SHIM6 performs context establishment.

The MN initiates streaming through the WiFi network using the INVITE message and gets approval, before the data transmission begins (4). In the event that the first connection drops due to handover, SHIM6 will failover to the second connection, thus the MN will not be required to re-register and can, given input from the SHIM6 layer, invoke for INVITE of the second stream through the GPRS network (5). As shown in Fig. 5, once the handover is initiated, an INVITE is only transmitted to the P-CSCF (V) to continue the session. This process in comparison to the Mobile IPv6 implementation, will result in less application disruption, in particular for multimedia content transmission.

In the event of downward handover, the handover latency will depend on whether the multihomed device contains the IP address of the WiFi network previously (this may be a visited network). In the event, that the device is entering a new network, the registration process is required, where the MN will listen to the RA from the visiting network, which will result in a handover latency operation similar to the Mobile IPv6 network.

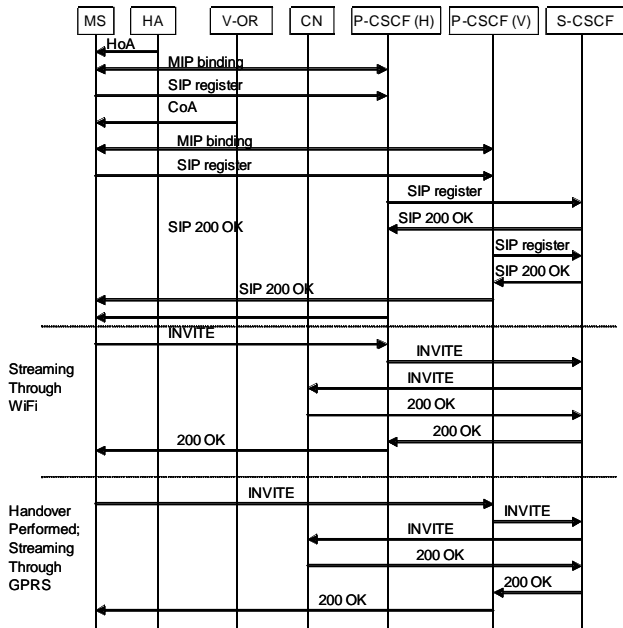

Figure 6. SHIM6 support for IMS sequence diagram.

6. Simulated tests

In order to compare SHIM6 and MIPv6 as mobility solutions, we designed and developed a stand-alone SHIM6 process model in OPNET. Our simulation work was performed to show how SHIM6 could be used to support mobility in IMS based Networks. This was then compared to MIPv6 in IMS networks. The handover was emulated by simulating the delay required to make a connection to the sip server on top of the delay required for the handover. We also built a multihomed node having two WLAN interfaces using OPNET's custom node creation facility. The SHIM6 model was then tested by integrating it into multihomed WLAN nodes, that communicated with each other using SHIM6 signaling.

A network scenario was built in which SHIM6 enabled WLAN node (MN) moved across different Access Routers (AR). A table was created in each AR, which contained subnet prefix of neighboring ARs. MN obtained these prefixes from currently attached AR. Figure 7 illustrates our network setup. Initially, when MN is attached to an AR, it configures and stores multiple addresses. In our model scenario we stored two addresses. One of the addresses is associated with AR1 while the other with AR2. During communication with CN, AR1 is taken to be MN's ULID. When MN moves into a new access domain, it detects the movement through Router Advertisement and uses SHIM6 to switch over to AR2 belonging to a different subnet. SHIM6 uses Update Request (UR) and Update Acknowledgement (UA) messages [5] to update context in a peer node. Hence, as MN moves into AR2's domain, it sends UR message to CN setting the preference to new address. CN thus updates MN's context and sends back UA. This allows data traffic flow between MN and CN to continue without much disruption during handoff. It results in lower end-to-end delay and packet loss. We compare the results with MIPv6 route optimization mode and present them. In addition, our proposed mechanism allows both endpoints of communication to perform handover simultaneously.

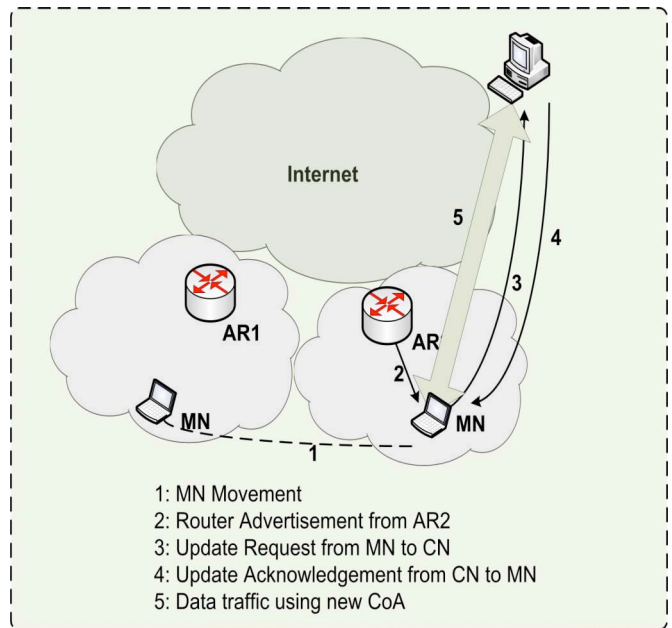

Figure 7. Simulation Network Setup.

Table 1 gives values of simulation attributes. MN communicated with CN while moving from AR1 to AR2 and back at a speed of 3 meters per second. Simulation time was 600 seconds

Table 1. Simulation Attributes.

| | |
|-------------------------------|--------------------|
| Simulated area | 100x100km |
| Number of communicating nodes | 2 |
| Simulation Time (sec) | 600 |
| Traffic Type | Video Conferencing |
| Number of AR | 2 |
| Speed (m/sec) | 3 |

Comparison was made between a) Traffic Received, b) Traffic Dropped, and c) Packet End to End Delay.

A) Traffic Received

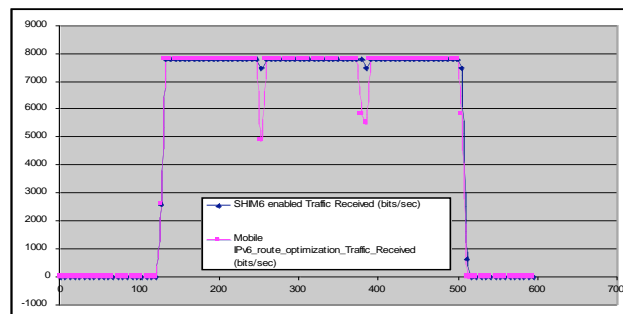

Figure 8. Traffic Received.

From the figure above, it can be concluded that there is much less traffic disruption in SHIM6 based mobility approach than in MIPv6 route optimization. This can be seen by the dips experienced by traffic in the two cases.

B) Traffic Dropped

Again, it can be seen from figure 9 that traffic dropped in SHIM6 enabled scheme is considerably less than in MIPv6 Route optimization scheme.

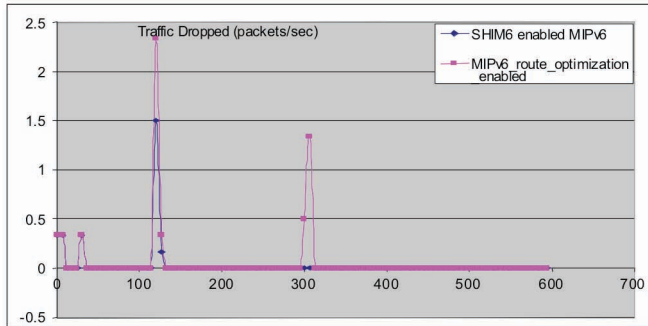

Figure 9. Traffic Dropped.

C) Packet End to End Delay

Figure 10 shows average packet End to End delay in two scheme. Again, it is clear that SHIM6 based Mobility scheme performs far better than MIPv6 Route Optimized Scheme. This is due to the fact that as Mobile Node moves to a new subnet, traffic is routed to new address much quicker than in Route Optimized MIPv6.

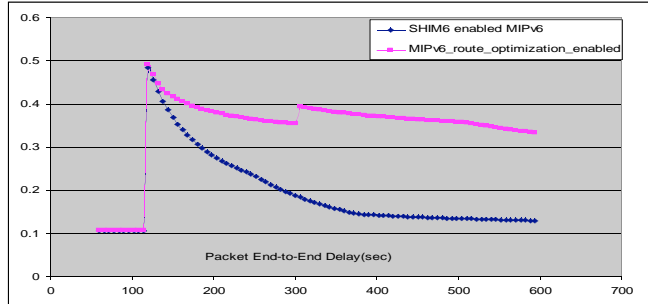

Figure 10. Packet End to End Delay.

7. Testbed

In order to perform a real world comparison, and attempt to validate the simulation results, the authors have begun testing an implementation of the SHIM6 protocol written by UCL in Belgium [9], this is written as a patch to the Linux kernel and is written to comply with the existing SHIM6 draft [5]. To this end a test-bed was assembled consisting of a SHIM6 enabled SIP Proxy, a multihomed SHIM6 Mobile Node and a IPv6 enabled Correspondent Node, much like in Figure 7. As the shim6 implementation is at a relatively early stage, the UR and UA messages are not yet implemented, which restricts our ability to conform to the scenario depicted in Figure 7.

As a consequence, it is not possible to add an interface to the context of a session already in progress. I.e. if a device has two interfaces and it commences a session with one interface ‘dead’ then that interface is considered ‘dead’, for the duration of the session.

What was possible to test, was a MN with two WLAN interfaces on two different IPv6 networks. After the commencement and establishment of a VoIP SIP call (via wireless interface 1), it was possible to manually drop an interface whereby the SHIM6 layer transferred the traffic to the alternative interface (wireless interface 2). When interface 1 was restored, it was possible to manually drop interface 2 and the SHIM6 layer, once again transferred the session. The average delay over a number of test runs was approximately 20ms to switch from interface 1 to interface 2 and 30ms to switch back from interface 2 to interface 1. The subjective user experience was that a faint ‘click’ was heard in the audio.

During some initial tests with MIPL 2.0[10] (a reference Mobile IPv6 implementation for Linux) using the same multihomed hardware configuration as above, the delay in restoration of audio at the MN was up to 10 seconds.

8. Conclusion

Future mobile networks will be required to support mobility as well as converged services. IMS networks provides multimedia services for future all-IP based networks. Although past research work has focused on integrating Mobile IPv6 with IMS networks, this work has led to low performance. A new approach towards supporting mobility is through the use of multihoming solution (SHIM6). In this paper, we propose to use SHIM6 support for mobility in IMS based networks. The proposed solution improves handover performance in comparison to Mobile IPv6 for IMS based networks. Simulation results have also been presented to describe this comparison from the perspective of number of traffic dropped, end-end delay, as well as degree of traffic disruption.

The test-bed realization needs further work in order to gather more data, as well as investigating what improvements in SHIM6 and the latest MIPL implementations have to offer.

9. ACKNOWLEDGEMENT

This work was funded by the ENABLE FP6 EU IST project.

10. REFERENCES

- [1] R.Charavorty, P. Vidales, K. Subramaniam, I. Pratt, J. Crowcroft, “Performance Issues with Vertical Handovers – Experience from GPRS Cellular and WLAN Hot-spots Integration. Proceedings of 2nd IEEE International Conference on Pervasive Computing and Communications (PerCom), Florida, USA, March 2004, pp.155-164.
- [2] S. Balasubramaniam, J. Indulska, “Vertical Handover supporting Pervasive Computing in Future Wireless Networks”, Computer Communications, 27, 2004, pp. 708-719.
- [3] C. Prehofer, N. Nafisi, Q. Wei, “A framework for Context-Aware Handover Decision”, Proceedings of PIMRC 2003, Beijing, China, September 2003.
- [4] F. Xu, L. Zhang, Z. Zhou, “Interworking of Wimax and 3GPP Networks based on IMS”, IEEE Communications Magazine, March 2007.
- [5] E. Nordmark, M. Bagnulo, “Level 3 multi-homing shim protocol”, Internet Draft (work in progress), IETF, October

2007. [Online]. Available: <http://www.ietf.org/internet-draft/draft-ietf-shim6-09.txt>

- [6] B. Aboba, IAB Considerations for the Split of Identifiers and Locators, draft-iab-id-locsplit-00.txt (work in progress), IAB, March 2004.
- [7] S. M. Faccin, P. Lalwaney, B. Patil, "IP Multimedia Services: Analysis of Mobile IP and SIP Interactions in 3G Networks", IEEE Communications Magazine, January 2004.
- [8] R. Chakravorty, P. Vidales, L. Patanapongpibul, K. Subramaniam, I. Pratt, J. Crowcroft, "On Inter-network

Handover Performance using Mobile IPv6", University of Cambridge Computer Laboratory Technical Report, May 2003.

- [9] UCL (Universite Catholique de Louvain shim6 implementation, February 2008, [Online], Available: <http://inl.info.ucl.ac.be/LinShim6>
- [10] Mobile IPv6 for Linux [Online], Available: <http://www.mobile-ipv6.org/>