

Galileo E1 and E5a Link-level Performance for Dual Frequency Overlay Structure

Jie Zhang*, Elena-Simona Lohan

Tampere University of Technology, Korkeakoulunkatu 10, FI-33720 Tampere, Finland

Abstract

The emerging European global satellite system Galileo has gained much public interest regarding location and position services. Two Galileo Open Service signals, namely E1 and E5, will provide the frequency diversity. The dual-frequency receiver will greatly enhance the performance of satellite navigation. However, the dual-frequency receiver becomes more complex since it needs to process two signals. Using common front-end components and common baseband for all the signals is a popular concept in literature in order to decrease the complexity. In this concept, two signals will be combined before the common baseband. The signals will then interfere with each other and the radio frequency (RF) interference in one signal band may also appear in other signal bands after the signal superposition. This article investigates the impact of interference due to the signal superposition on code tracking.

Keywords: Galileo, E1/E5a, dual frequency receiver, common baseband, signal superposition, interference, code tracking, Simulink, simulators.

Received on 30 September 2011; accepted on 5 January 2012; published on 29 March 2012

Copyright © 2011 Zhang and Lohan, licensed to ICST. This is an open access article distributed under the terms of the Creative Commons Attribution licence (<http://creativecommons.org/licenses/by/3.0/>), which permits unlimited use, distribution and reproduction in any medium so long as the original work is properly cited.

doi: 10.4108/trans.ubienv.2012.e3

1. Introduction

Satellite navigation is a process of providing autonomous global geo-spatial position with coverage all over the world. The navigation technology is essential for several civil applications, such as in the transportation field (e.g., road, rail and aviation). Other applications, such as precision agriculture, wildlife behaviour monitoring, surveying and time based applications are also based on the estimation of users' Position, Velocity and Time (PVT) [1]. These applications, especially the ones dedicate to safety, require high accuracy of users PVT estimation.

The increasing demands for navigation services have also accelerated the advent of new navigation systems. By

2020 there will probably be at least three independent Global Navigation Satellite Systems (GNSS) available: GPS, GLONASS and Galileo. However, conventional navigation devices usually receive only a single frequency satellite signal coming from only one system and the receivers may suffer from sever performance degradation in GNSS-challenged environment, such as urban areas. Moreover, various sources of radio-frequency interferences (RFI), both wideband and narrowband, interfere with the received satellite signal. Despite the growing need for accurate and reliable satellite positioning, the above-mentioned issue still severely limits the achievable system performance.

Utilizing dual frequencies could greatly enhance the performance of satellite navigation. For example, one of the error sources for satellite navigation, the RFI, either intentional or unintentional, represents an impairing factor in GNSS application mainly due to the low power of the GNSS signal at the earth surface. This RFI is likely to

*Corresponding author, Email: jie.zhang@tut.fi

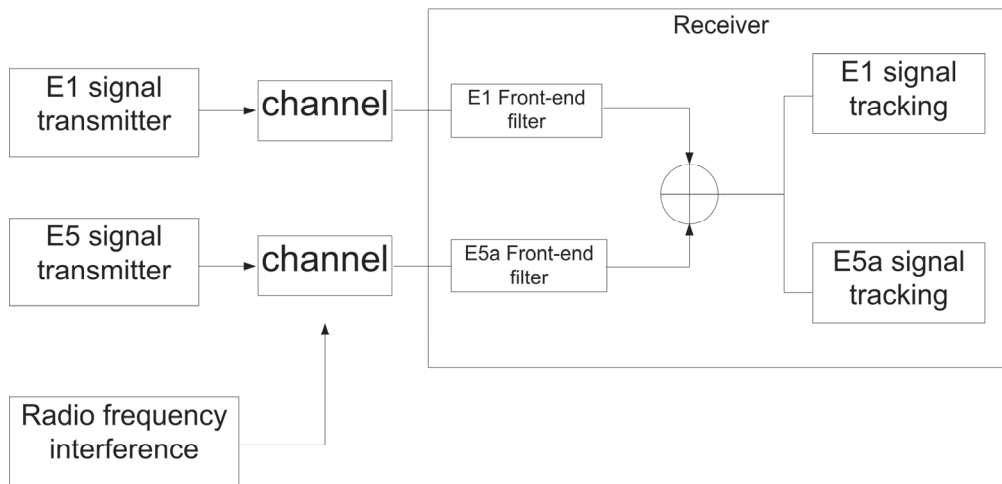

Figure 1. Block diagram of simulator

affect only one of the two frequencies, thus receiving the signal through dual frequency may enhance the results. Indeed, the frequency diversity will provide better robustness against interference since one signal band may still be used while the other is jammed [2]. In addition, two frequencies can be used to correct the ionosphere error if the higher order effects are ignored, so that a higher positioning accuracy can be provided. Moreover, a dual-frequency receiver could have a better performance in multipath mitigation, through different phases of the reflections of the difference frequencies [3]. For the reason above, we believe that the dual-frequency receiver implementation will be the main trend in the next generation receivers as soon as the signals become available.

The dual-frequency receiver, however, becomes more complex since it needs to process the signals from two frequencies. One well-known concept to reduce the complexity is to share the same front-end components and to use one common baseband stage [2][4]. In this method, two signals will be combined before the common baseband stage as shown in [2]. However, the superposition of signals may bring some problems. For example, if the Intermediate Frequencies (IF) of signals are close to each other in the baseband, the signals may interfere with each other. This will affect the accuracy of code tracking on both signals. In addition, if there is RFI within one signal band, it might also appear in other signal bands after signals' superposition. The RFI may degrade the tracking performance of both signals. To the author's knowledge, these two problems have not been evaluated much in the literature so far. The goal of this article is to investigate the impact of signal superposition on code tracking accuracy in a dual frequency receiver

from two aspects: 1) choice of relative IF for two signals in a dual frequency receiver; 2) the impact of RFI. The signals considered in this article are Galileo E1 and E5a signals. This is because the E1/E5a combination is the optimal solution for mass-market dual frequency receivers from the hardware implementation point of view [4]. The characteristics of E1 and E5 signals are summarized in Table 1 [5]. CBOC here stands for Composite Binary Offset Carrier modulation [6] and AltBOC for Alternate Binary Offset Carrier modulation [7]. The investigation has been conducted with two Simulink Tx-Rx chain simulators for Galileo E1 and E5 signals [8], respectively. These two simulators are built at Tampere University of Technology (TUT) in Finland.

The rest of the paper will be organized as follows: next section introduces the simulator used in this article and some details of the main blocks in the simulator. Then, the simulation setup and results will be presented in Section 3; finally, the conclusions are drawn in Section 4.

Table 1. Parameters of E1 and E5 signal

	E1 signal	E5 signal
Modulation type	CBOC(6,1)	AltBOC(15,10)
Chip rate (MHz)	1.023	10.23
Carrier frequency (MHz)	1575.42	E5: 1191.795 E5a: 1176.45 E5b: 1207.12
Reference BW (MHz)	24.552	E5: 51.15 E5a: 20.46 E5b: 20.46

2. Simulink model overview

2.1 Generic simulator structure

Simulation is a powerful method in the analysis and design of communication devices. The research on new signals, which are not available in the sky, can be done through simulations [9]. The simulators for E1 and E5a signals used in this article for evaluating the tracking performance were created at TUT, under Simulink from Mathworks. Two simulators were combined in order to conduct the simulations in this article. The block diagram of this modified simulator is as shown in Figure 1.

2.2 Before the signals superposition

As shown in Figure 1, the E1 and E5 signals are first generated separately in two transmitter blocks. The transmitters generate the whole band E1 and E5 signals. The two signals may be passing through common or different wireless channels, depending on the relative location of the transmitters (satellites). Here, we assume E1 and E5 signals are coming from the same satellite, so the channel power-delay profiles are identical to E1 and E5 signals. However, it is to be mentioned that these common channel profile will affect differently the E1 and E5a signals, since they operate at different chip rates and different IF. After passing through the channel, the signals are captured by the receiver and filtered by the front-end filters. The main details about each block are introduced in the text as followed.

2.2.1 E1 signal transmitter

The E1 signal transmitter block is implemented based on CBOC modulation, including primary code and secondary code, in the accordance with the latest Galileo OS SIS ICD [5]. In the E1 signal transmitter block, E1B channel uses a CBOC(+)- modulated signal with navigation data and E1C channel uses a CBOC(-)-modulated signal with a pre-defined bit sequence of CS25[10]. The E1 signal is formed as the difference between those two signals. The signal at the output of the transmitter is at IF.

2.2.2 E5 signal Transmitter

The E5 signal transmitter generates the whole E5 signal. The E5aI, E5aQ, E5bI and E5bQ are modulated by using AltBOC(15,10) 8-PSK modulation, as described in [5]. The whole E5 signal is transmitted at IF at the output of the E5 signal transmitter. The IF for E5 signal may be different than the IF for E1 signal.

2.2.3 Channel blocks

The channel block generates the multipath signals and complex noise for a user-defined Carrier to Noise density ratio (C/N_0), multipath delay and power. In this article, we

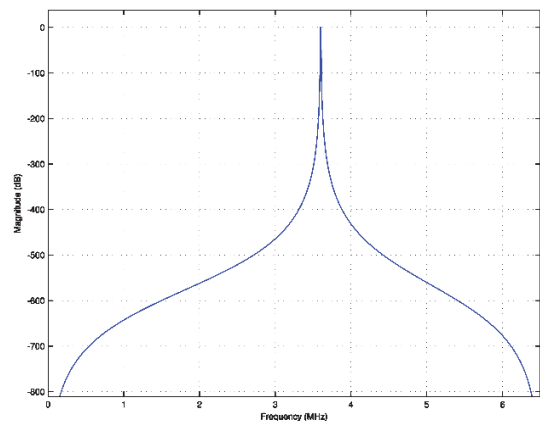

Figure 2. Example of bandpass filter use for generating narrowband interference

only consider the single path scenario in order to focus on the effect of RFI.

2.2.4 Front-end filters

The front-end blocks are used for receiver front-end filtering. They are Chebyshev type I bandpass filters with order 6. There are several front-end bandwidths can be used, e.g., infinite bandwidth for the ideal case, 4 MHz which can cover the main lobe of E1 signal power spectrum and 20.46 MHz for E5a signal.

2.3 Radio frequency interference

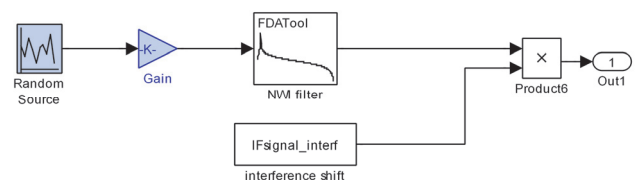

Figure 3. Interference generation

The possible external interference is generated separately. In this article, we assume the external interference is narrowband radio frequency interference. This interference is generated in such a way that the white Gaussian noise passes through a bandpass filter (see Figure 2 and Figure 3). The filtered noise can be shifted to different carrier frequencies.

2.4 Tracking stage

The filtered E1 and E5a signals are combined before the tracking stages. Since the common baseband structure

contains a number of tracking channels and each channel is capable of processing one signal at a time, therefore, the tracking stages in this simulator are implemented separately for E1 and E5a signals. The E5a signal tracking stage processes only E5a signal. The function of blocks including in the tracking stage will be introduced next.

In both E1 and E5a tracking channel, the tracking stage consists of three main blocks: carrier wipe-off block, code Numerically Controlled Oscillator (NCO) block and dual channel correlation and discriminator block.

In the carrier wipe-off block, the received signal is down-converted to the baseband with the estimated frequency and phase from Phase Lock Loop (PLL) and Frequency Lock Loop (FLL) in the tracking loop.

The “code NCO” block generates the local Pseudorandom Noise (PRN) reference code, which is shifted by the estimated code phase from Delay Lock Loop (DLL). According to the correlator offset and the status of phase holding shifter, the local reference codes are determined. In E1 signal receiver, the local reference codes are generated separately for E1B and E1C channel, respectively. In E5a signal receiver, only In-phase E5a signal is generated.

Table 2. Signal simulator parameters

Parameters	Typical value
Sampling frequency in E1 transmitter	52
Sampling frequency in E1 tracking (MHz)	52
Intermediate frequency IF for E1 signal (MHz)	3.42
Early-Late correlator spacing in E1 tracking (chips)	Bandwidth dependent $\Delta_{E-L} \geq fc_{E1}/Bw$
Reference code in E1 tracking	SinBOC(1,1) modulated E1B and E1C
Sampling frequency f_s in transmitter (MHz)	104
Sampling frequency in tracking (MHz)	52
IF for whole E5 signal (MHz)	15.34
IE5a frequency f_{E5a} (MHz)	10.23
Early-Late correlator spacing in E5a tracking (chips)	Bandwidth dependent $\Delta_{E-L} \geq fc_{E5}/Bw$
Reference code in E5a tracking	E5aI code

In the dual channel correlation and discriminator block, FLL and PLL and DLL are included. In the DLL discriminator block, various conventional discriminator

functions are implemented, such as narrow correlator [11], Multiple Gate Delay (MGD) [12][13] and two-stage estimator [14]. In the simulation, only the narrow correlator is used. The main parameters used in the E1 and E5a signal Simulink model are summarized in Table 2.

3. Simulations

The simulations have been done with the simulator introduced above. In all the simulations, the power level of the desired signal and thermal noise were set to produce a signal with C/N_0 of 55 dB-Hz. The narrow correlator was used in the discriminator in both E1 and E5a tracking stage. The impact of different IF values and narrowband interference was investigated. The details of the simulation setup and results are shown in the next section. The simulation parameters are summarized in Table 3.

Table 3. Simulation parameters

Simulation parameters	Value
C/N_0	55 dB-Hz
Front-end bandwidth	E1: 4MHz E5a: 20.46 MHz
Discriminator	Narrow Correlator
Impact on IF on code tracking simulations	
E5a IF	10.23 MHz
E1 PSD IF shift relative to E5a PSD	0:1.023:10.23MHz
Impact of Narrowband interference simulations	
Narrowband interference bandwidth	10 kHz

3.1 Impact of IF on code tracking

3.1.1 Simulation setup

In order to find the effect of the choice of IF value for E1 and E5a signals, we configured the simulator as follows: as shown in Figure 4, the E5a signal stays at a fixed IF, 10.23 MHz and the E1 signal is shifted to different IF. Since the signals will not interfere with each other when the E1 and E5a signal spectrums are not overlapping, therefore, we only evaluate the effect on code tracking when the E1 and E5s spectrum are overlapped. The effect on code tracking for E1 and E5a signals are evaluated separately.

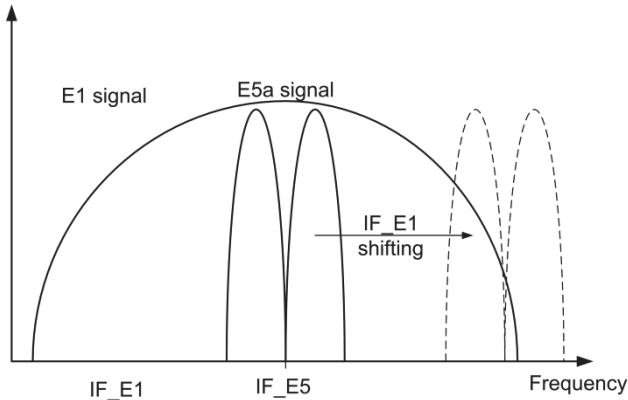

Figure 4. Illustration of IF shifting in simulation

3.1.2 Simulation results

The simulation results for evaluating the effect of IF for E1 and E5a signals are shown in Figure 5 and Figure 6. As can be seen from the Figure 5, the signal superposition degrades a little the code tracking performance compared with of the performance without signal superposition. For both E1 and E5a tracking, the code tracking error increases about 0.2 m. The relative position of IF for E1 and E5a signals does not have significant effect on the code tracking. On the other hand, the variance of E1 code tracking error is doubled after the signal superposition, as seen in Figure 6. The variance of E5a tracking error does not increase much. This is because of the fact that the bandwidth of E1 signal is much smaller than the bandwidth of E5a signal. The E1 signal interferes only in a part of the E5a signal.

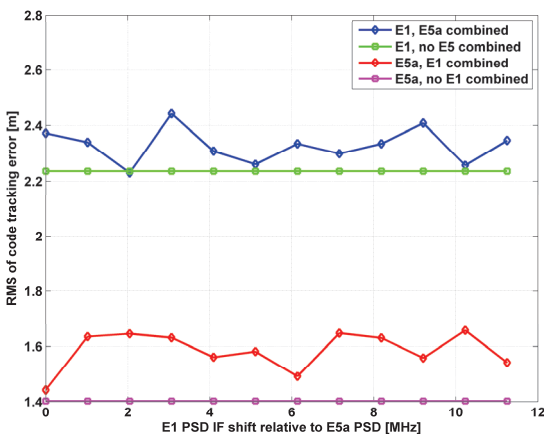

Figure 5. RMS of code tracking error for E1 and E5a signal

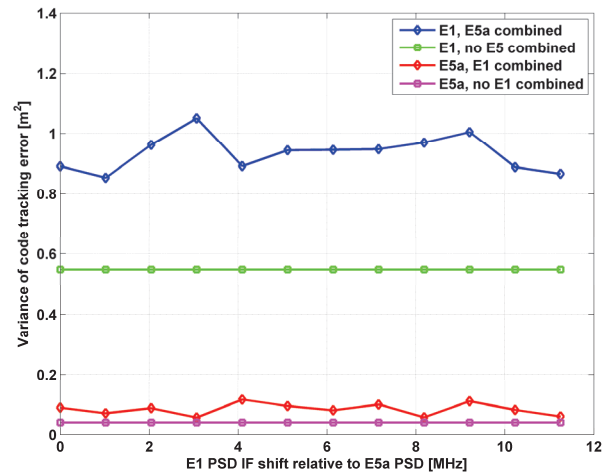

Figure 6. Variance of code tracking error for E1 and E5a signal

3.2 Impact of narrowband interference

3.2.1 Simulation setup

In order to evaluate the impact of the RFI introduced by the signals' superposition, we fixed the IF for the E5a signal at 10.23 MHz, and IF for the E1 signal at 12.25 MHz. This value was chosen from the local minimum value in E1 tracking as shown in Figure 5.

In the evaluation on code tracking of both signals, we are interested in finding out what is interference level introduced by one signal band into another signal band. As shown in Figure 7, when the interference is originally within E1 signal band, the interference will also appear in E5a signal band after superposition. However, if the interference exists only within the E5a signal band before superposition, the interference may not appear in the band of E1 signal after superposition, as shown in lower diagram in Figure 7. Since the interference cannot be filtered out in the tracking stage, the interference may still have some impact on the code tracking accuracy. Therefore, the simulations for E1 signal tracking were done with interference located within the whole E5a band. The aim is to see the differences between the tracking with and without signal superposition in the presence of narrowband interference. The narrowband interference was generated as described in Section 2. The simulation parameters were summarized in Table 3.

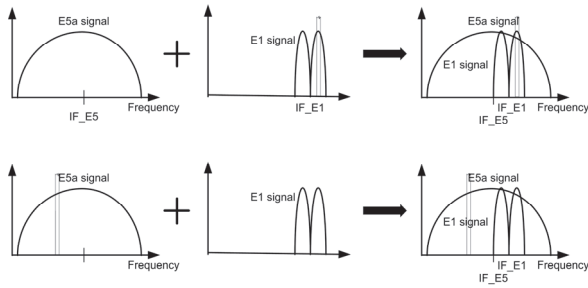

Figure 7. Illustration of signal superposition in the presence of narrowband interference

3.2.2 Simulation results

Figure 8 presents the results of E1 signal code tracking error after signal superposition when the interference is brought in E1 signal band from E5a signal band. As it can be seen in the figure, the interference in E5a band has a significant effect on E1 signal tracking accuracy, no matter whether the interference is within the E1 signal band after the superposition or not. If the interference is located at $1 \cdot f_c$ away from the IF of E1 signal, the RMS of E1 code tracking error is up to 400 meters when the interference is located within the E1 signal band and when the interference to signal power ratio (ISR) is 40 dB. The effect on code tracking is getting smaller when the interference is moving far away from the E1 band. We also found that, when the ISR is getting higher, the degradation on code tracking is getting bigger. The ISR threshold is between 25 dB and 30 dB, which means that, when the interference is below this threshold, the narrowband interference effect on code tracking is negligible.

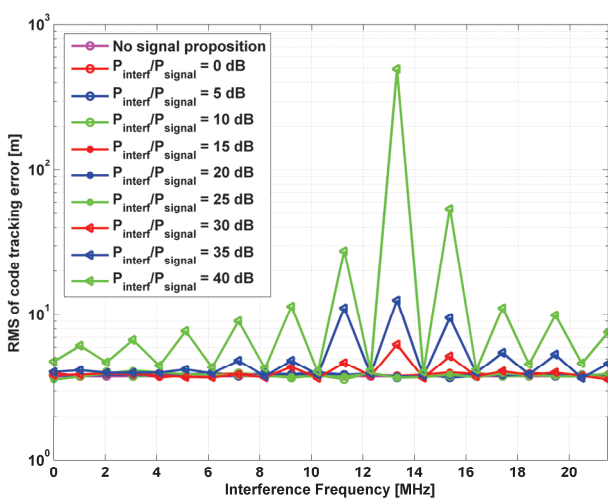

Figure 8. RMS of E1 code tracking error when the E5a signal introduces RFI to E1 signal

Figure 9 shows that the RMS of E5a code tracking error when the E1 signal introduces RFI to E5a signal. As it can be seen from the figure, compared with the situation of without signal superposition (no RFI introduced to E5a), we can observe that the interference introduced by the E1 signal have very little effect on tracking E5a signal if the ISR is less than 25 dB. When the ISR is up to 40 dB, the E5a signal code tracking performance is significantly degraded. We also found that, E5a signal is much more robust against narrowband interference than E1 signal. It is because of the high chip rate and wideband width.

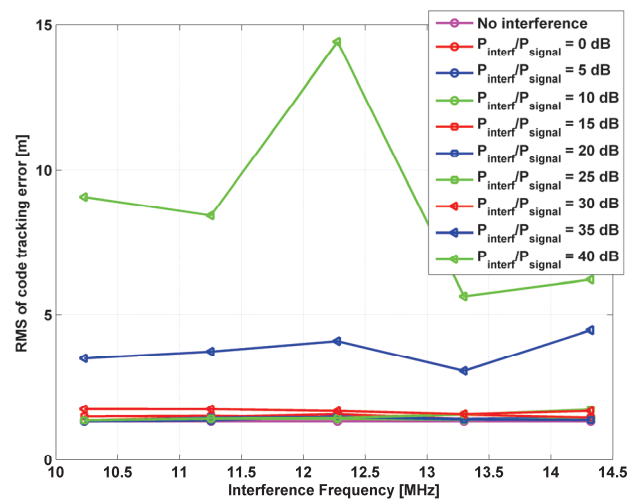

Figure 9. RMS of E5a code tracking error when the E1 signal introduces RFI to E5a signal

4. Conclusions

In this article, we analyzed the effect of signal superposition on code tracking. The evaluation was conducted with a Simulink simulator, including signal transmitters, propagation channels, front-end filter and signal tracking stages. The simulation results showed that the overlapping of two signal bands did not have much effect on either signal's code tracking. However, the noise level was increased much, especially on E1 signal.

We also evaluated the effect of interference, which is introduced from one signal band to another signal band. The results showed that there were significant effects on code tracking accuracy. If the interference introduced by E5a signal was not located in the E1 signal band after the superposition, the code tracking performance was still affected by the interference. The results also indicated that the E5a signal was more robust against the interference than E1 signal.

For future work, taking advantage of common baseband structure in the dual frequency receiver to avoid interference and improve the tracking performance will be conducted.

Acknowledgements

The research leading to these results has received funding from the European Union's Seven Framework Programme (FP7/2007-2013) under the grant agreement n227890 (GRAMMAR project) and from Academy of Finland, which are gratefully acknowledged. The author would also like to thank Nokia Foundation and Tekniikan edistämissäätiö (TES) for their support.

References

- [1] B. Motella, S. Savasta, D. Margaria, F. Dovis, A Method to Assess Robustness of GPS C/A Code in Presence of CW Interference, *Hindawi International Journal of Navigation and Observation*, "Special Issue: Integrating Radio Positioning and Communications: New Synergies", Vol.2010, pp1-8, ISSN:1687-5990, June1, 2010
- [2] Rugamer, A., Mongredian, C., Urquijo, S.; Rohmer, G.; (2011) Optimal path-control for dual-frequency overlay GNSS receivers, *International Conference on Localization and GNSS (ICL-GNSS)*, vol., no., pp.158-163
- [3] Akos, D.M., Ene, A., Thor, J., (2003) A Prototyping Platform for Multi-Frequency GNSS Receivers, *Proceedings of the 16th International Technical Meeting of the Satellite Division of The Institute of Navigation (ION GPS/GNSS)*, Portland, OR, pp. 117-128.
- [4] Hurskainen, H.; Lohan, E.-S.; Nurmi, J.; Sand, S.; Mensing, C.; Dettratti, M.; (2009) Optimal dual frequency superposition for Galileo mass market receiver baseband, *Signal Processing Systems, SiPS. IEEE Workshop on*, vol., no., pp.261-266
- [5] Galileo Open Service Signal In Space Interface Control Document, OD SIS ICD, Issue 1 (2010)
- [6] G. W. Hein, J. A. Avila-Rodriguez, S. Wallner, A.R. Pratter, J. Owen, J. L. Issler, J. W. "MBOC, The new optimized spreading modulation recommended for Galileo L1 OS and GPS L1C", in *Position, Location, And Navigation Symposium*, 2006, IEE/ION, pp. 883-892, April 2006
- [7] Sleewaegen, J.M., De Wilde, W., Hollreiser, M., "Galileo AltBOC Receiver", in *Proc. Of ENC-GNSS*, May 17, 2004, Rotterdam
- [8] Simulink open source software for Galileo E1 signals, [Http://www.cs.tut.fi/tlt/pos/Software.htm](http://www.cs.tut.fi/tlt/pos/Software.htm), Tampere University of Technology, accessed March 2011.
- [9] Borre, K., Akos, D.M., Bertelsen, N., Rinder, P. and Jensen. S.H., *A Software-Defined GPS and Galileo Receiver: A single-Frequency Approach*. Birkhäuser Boston, 2007.
- [10] Hein, G.W., Godet, J., Issler, J.L., Martin, J.C., Erhard, P., Rodridus, R.L., Pratt, T. (2002) Status of Galileo Frequency and Signal Design. In *Processing of ION GPS*, Oregon Convention Center - Portland, Oregon
- [11] Dierendonck, A.V., Fenton, P. And Ford, T. (1992) Theory and performance of narrow correlator spacing in a GPS receiver, *Journal of the Institute of navigation*, vol. 39, pp. 265-283
- [12] Zhang, J. and Lohan, E.S.; , Multi-correlator structures for tracking Galileo signals with CBOC and SinBOC(1,1) reference receivers and limited front-end bandwidths (2010), In *Proceedings of Positioning Navigation and Communication (WPNC)*, Dresden, 11-12 March, pp.179-186
- [13] Hurskainen, H., Lohan, E.S., Hu, X., Raasakka, J. and Nurmi, J. (2008) Multiple Gate Delay Tracking Structures for GNSS Signals and Their Evaluation with Simulink, SystemC, and VHDL," *International Journal of Navigation and Observation*, vol. 2008, Article ID 785695, 17 pages, 2008.
- [14] Bhuiyan, M. Z. H., Zhang J., and Lohan, E. S. (2010) Enhanced Delay Tracking Performance of a C/N0-based Two-Stage Tracker for GNSS Receivers, *European Navigation Conference on Global Navigation Satellite Systems, ENC GNSS 2010*, 19 - 21 October, 2010, Braunschweig, Germany