

# Designing and Analysing an APP based on "Internet+" for Integrating Health Data of University Physical Classes

Shuaishuai Zhang<sup>1,3</sup> and Gang Chen<sup>2,3\*</sup>

<sup>1</sup>Physical Education School of Jining University, Qufu 273155, Shangdong, China.

<sup>2</sup>School of Arts and Sports Nanchang Normal College of Applied Technology, Nanchang 330000, Jiangxi, China.

<sup>3</sup>International College of Philippine Christian University, Manila1004, Manila, Philippines.

## Abstract

**INTRODUCTION:** University physical education programs still largely use traditional methods without significant innovation in teaching or health evaluation. With the growing capabilities of Internet technology and artificial intelligence, there's a critical need to leverage these advancements to enhance the physical health assessments of college students.

**OBJECTIVES:** The study proposes an integrated APP design for health data collection and analysis both inside and outside physical education classes, utilizing Internet technologies and intelligent learning algorithms. This is aimed at precisely analyzing and improving the health outcomes of university students by fostering more tailored and responsive physical education experiences.

**METHODS:** The method involves constructing an app design analysis index system, integrating a vulture search heuristic optimization algorithm with a convolutional neural network (CNN). This setup uses smart sports APP behavioral data as input to refine and optimize health data integration, aiming to enhance the analysis and feedback mechanisms within university sports programs.

**RESULTS:** The implementation of this method showed that it meets real-time requirements while significantly improving the accuracy and efficiency of integrated APP design analyses for health data. The use of smart algorithms allows for more precise adjustments and feedback in physical education programs, suggesting a substantial improvement over traditional physical health monitoring and evaluation methods.

**CONCLUSION:** The proposed APP design successfully integrates and analyzes health data, enhancing the management and evaluation of physical education programs. It represents a significant step forward in utilizing modern technology to address the stagnation in physical education health monitoring, with potential implications for broader educational and health management practices in universities. Future iterations of the APP could incorporate more diverse data inputs and advanced analytical features to further refine its effectiveness and usability.

**Keywords:** health data integration app, internet+, vulture search algorithm, convolutional neural network

Received on 16 January 2024, accepted on 28 April 2024, published on 3 May 2024

**Copyright** © 2024 Zhang *et al.*, licensed to EAI. This is an open access article distributed under the terms of the [CC BY-NC-SA 4.0](#), which permits copying, redistributing, remixing, transformation, and building upon the material in any medium so long as the original work is properly cited.

doi: 10.4108/eetpht.10.5856

\*Corresponding author. Email: Christian270@126.com

## 1. Introduction

According to the basis of the construction and implementation of university physical education programmes in China, the construction of university physical education in China has entered the stage of the development of sports power in the new era [1]. With the development of Internet technology and artificial intelligence technology, the university physical education programme still adopts the traditional way of education, the reform of the physical education curriculum has not made any breakthrough progress, there is no substantial change in teaching evaluation, and the physical health level of college students is still in a downward trend [2]. The advancement of Internet and big data technologies has facilitated the "Internet + education" initiative, which enhances university physical education courses through smarter, more interconnected, systematic, and scientifically developed approaches [3]. The research on the integration of the Internet and physical education curriculum does not only include the application of the Internet in physical education teaching, network-based physical education evaluation methodology research, etc. [4]. Literature [5] selected papers related to journals so as to understand the teaching-related foreign preface research; literature [6] studied the evaluation method of the determinants of teaching style; literature [7] improved the teaching evaluation mode from the three aspects of the evaluation subject, the evaluation index system, and the evaluation method to improve the credibility and accuracy of the teaching evaluation, and to promote the evaluation subject's subjectivity; literature [8] studied the physical fitness assessment-based Literature [8] studied the physical fitness assessment-based evaluation method of physical education, and analysed the content of teaching evaluation; Literature [9] proposed the evaluation method of physical education teaching based on "Internet +"; Literature [10] combined machine learning algorithms, analysed the APP application of physical education courses based on "Internet +", and constructed an APP application analysis model. and constructed an APP application analysis model. From the existing literature on the combination of physical education and Internet technology and the research results of previous researchers, although there has been a long time and a large number of studies on the analysis of physical education software applications, there is a lack of quantitative analysis of physical education APP research, and it fails to form an APP application analysis and evaluation method, which leads to the integration of physical education and Internet technology is not precise, objective and scientific enough [11].

Aiming at the problems existing in the current APP design and analysis method for teaching university physical education courses [12], this paper proposes an APP design and analysis method for teaching university physical education courses based on "Internet+" and optimisation

algorithm to improve the deep learning network. In this paper, we analyze the APP design framework for "Internet+" university physical education internal and external health data integration, extract the APP design analysis indexes, improve the convolutional neural network by combining the animal behaviour heuristic optimization algorithm, and construct the APP design analysis method for "Internet+" based on the intelligent optimization algorithm and convolutional neural network. Intelligent optimisation algorithm and convolutional neural network to construct the APP design analysis model for "Internet+" based on the integration of health data inside and outside the university physical education class. The effectiveness and feasibility of the proposed method is verified by comparing the training behaviour data of the network platform with the algorithms of other references.

## 2. Design of an integrated app for health data in and out of college physical education classes Framework

### 2.1. APP Design Framework

This paper takes university physical education course teaching as the object of analysis, and analyses and describes the integrated APP design method for health data in and out of university physical education classes.

In the context of the era of big data, scientific research will pay more attention to discovering and predicting the development trend of things and their inner laws [13]. In order to know more about students' sports and health big data, this section is based on the concept of big data, Internet + and intelligent sports curriculum development, to improve students' health awareness, social adaptation, exercise habits, physical fitness as a guide, based on the APP monitoring of smart wearable devices as a means, through interviews with relevant experts and teachers, students, from the teaching needs and students' needs, to build and design the university physical education inside and outside the classroom Health data integration APP framework, the specific framework is shown in Figure 1. As can be seen from Figure 1, the integrated APP of health data inside and outside university physical education classes under the background of "Internet+" mainly includes data collection, data analysis, data application and other functions. Data collection is mainly through the sports bracelet, physical fitness test, indoor and outdoor readers, tablet attendance terminals and other inputs to collect data; data analysis is mainly combined with intelligent algorithms to analyse and mine the user behaviour data; data application is mainly to the results of the data analysis of the college students' physical education courses in the guidance and feedback.

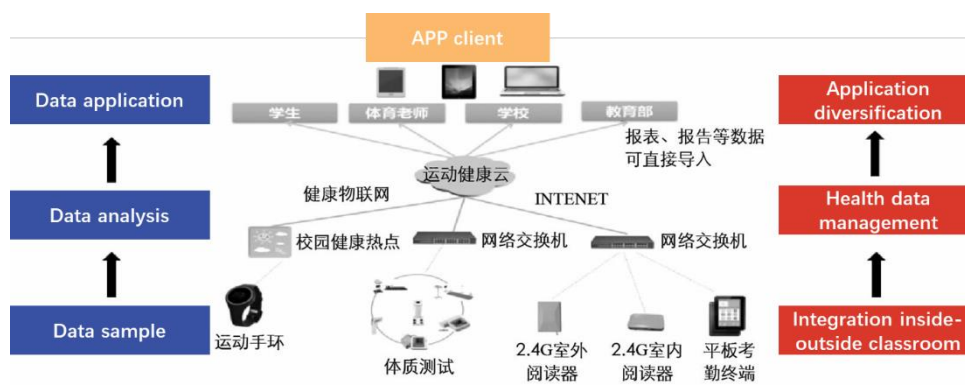


Figure 1 App design for integrating health data in and out of university physical education classes

## 2.2 APP design analysis index extraction

In order to construct the APP design analysis index system for the integration of health data inside and outside university physical education classes under the background

of "Internet+", according to the APP design framework, we extracted the indicators for the integration of health data inside and outside university physical education classes from the three aspects of data collection, data analysis, and data application [14]. are shown in Figure 2.

User behavior data characteristics		
Data sample function	Data analysis function	Data application function
Real-time physical sign data	Data visualization	Health management
Real-time exercise data	Exercise rationality	Health intervention
Physical health data	Exercise habit	Classroom management and evaluation

Figure 2 Extraction of indicators for analysing the design of an integrated app for health data in and out of university physical education classes

### (1) Data collection aspects

How to collect useful information from massive data in the context of big data is one of the key factors in the development of big data. The data collected from the integration of health data inside and outside the university physical education class include students' real-time physical signs data (heart rate, height, body mass, sleep, etc.), real-time exercise data (exercise time, exercise frequency, exercise location, exercise programme, etc.), and physical health data (individual physical test scores, comparison of physical health tests) [15]. The extracted APP design analysis metrics include real-time physical signs data S1, real-time exercise data S2, and physical health data S3.

### (2) Data analysis aspects

Sports big data analysis is the use of smart wearable devices and other forms of big data collected, after further storage, organisation, visualisation, to play the maximum

efficacy of the data [16]. The extracted indicators of data analysis aspects include data visualisation F1, reasonableness of exercise in and out of class F2, and exercise habituation F3.

### (3) Data application aspects

The application of big data as the main feature of the development of big data in sports, after obtaining certain results through the analysis of data by the big data analysis platform, and further applying the results to the actual practice, in order to achieve the benign development of promoting students to strengthen physical exercise [17]. The extracted indicators of data application include health management Y1, health intervention Y2, and classroom management and evaluation Y3.

## 2.3 Construction of the index system for analysing the integrated APP design for

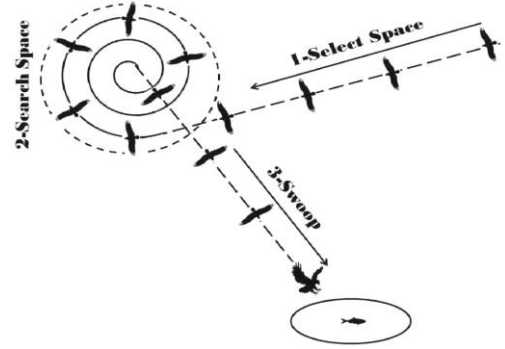
## health data inside and outside university physical education classes

The university physical education in-class and out-of-class health data integration APP design analysis index system takes the functional aspects of data collection, data analysis, and data application [18] as the first-level indicators, and takes the real-time physical signs data S1, real-time exercise data S2, physical health data S3, data visualisation F1, in-class and out-of-class workout reasonableness F2, exercise habituation F3, health management Y1, health intervention Y2, classroom management and Evaluation Y3 and other 9 analysis elements as secondary indicators [19], which fully reflects the overall nature of the university physical education in-class and out-of-class health data integration APP design framework, and constructs a scientific, objective and systematic APP design analysis index system.

### 3. Related Technologies

#### 3.1 Vulture Search Algorithm

Bald Eagle Search optimization algorithm (BES) is a novel, nature-inspired meta-heuristic optimization algorithm proposed by Malaysian scholars Alsattar et al [20] in 2020 by simulating the intelligent social behaviours of bald eagles while hunting fish. Compared with other intelligent algorithms, BES has a strong global search capability and can effectively solve various types of complex numerical optimisation problems. Bald eagles are found throughout the North American region, with sharp eyesight and excellent observation ability in flight. Taking salmon predation as an example, the bald eagle will firstly select the search space based on the concentration of individuals and populations to salmon, and fly towards a specific area; secondly, search the water surface within the selected search space until it finds a suitable prey; finally, the bald eagle will gradually change the flight altitude and quickly dive downwards to successfully capture the salmon and other preys from the water. The Bald Eagle Search Algorithm (BES) simulates the behaviour of the bald eagle during the hunting process in order to justify the synergistic sequence of the hunting phases. Inspired by this, the BES algorithm can be divided into three parts, i.e., selecting the search space, searching within the selected search space and swooping [21]. The three important phases of the BES algorithm are shown in Figure 3.



**Figure 3** Three phases of the BES algorithm

##### (1) Selection phase

In the selection phase, bald eagles identify and select the best areas (areas with high food availability) within the selected search space where they can hunt for prey. The specific model is as follows:

$$P_{i,new} = P_{best} + \alpha \cdot r \cdot (P_{mean} - P_i) \quad (1)$$

where  $\alpha \in [1.5, 2]$  is the parameter controlling the position change,  $r$  is a random number in the interval  $(0, 1)$ ;  $P_{best}$  denotes that the search space currently selected by the bald eagle based on the best position is recognised;  $P_{mean}$  denotes the average distribution of all positions previously searched by the bald eagle; and  $P_i$  denotes the position of the  $i$ th bald eagle.

##### (2) Search phase

In the search phase, the vulture searches for prey in the selected search space and moves in different directions in the spiral space to accelerate the search, as shown in Figure 4. The spiral flight mathematical model uses polar coordinate equations for position updating, which are calculated as follows:

$$\theta(i) = a \cdot \pi \cdot rand \quad (2)$$

$$r(i) = \theta(i) + R \cdot rand \quad (3)$$

$$xr(i) = r(i) \cdot \sin(\theta(i)) \quad (4)$$

$$yr(i) = r(i) \cdot \cos(\theta(i)) \quad (5)$$

$$x(i) = xr(i) / \max(|xr|) \quad (6)$$

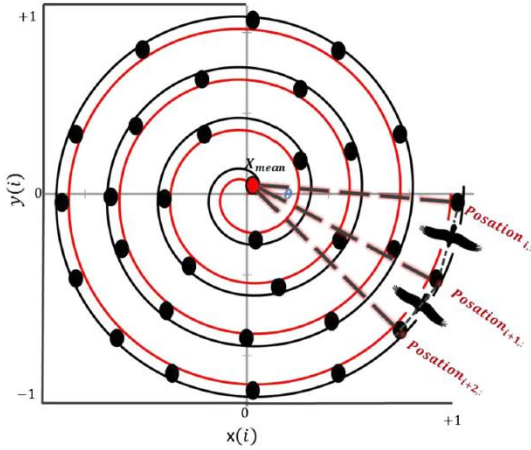
$$y(i) = yr(i) / \max(|yr|) \quad (7)$$

Where  $a \in (5, 10)$  denotes the angle between the centre point and the search point,  $R \in (0.5, 2)$  denotes the number of search cycles,  $\theta(i)$  and  $r(i)$  are the polar angle and polar diameter of the helix equation,  $rand$  denotes a random number between 0 and 1, and  $x(i)$  and  $y(i)$

denote the position of the bald eagle in polar coordinates, which takes the value  $(-1,1)$ . The formula for updating the bald eagle position in polar coordinates is as follows:

$$P_{i,new} = P_i + y(i) \cdot (P_i - P_{i+1}) + x(i) \cdot (P_i - P_{mean}) \quad (8)$$

where  $P_{i+1}$  indicates the next position of the bald eagle.



**Figure 4** Search phase of the BES algorithm  
(3) Swooping Predation Stage

In the swooping predation phase, the condor swings from the optimal position in the search space to the target prey, and all search points move towards the optimal point.

This movement is also described using polar coordinates, which are calculated as follows:

$$\theta(i) = a \cdot \pi \cdot rand \quad (9)$$

$$r(i) = \theta(i) \quad (10)$$

$$x_1(i) = xr(i) / \max(|xr|) \quad (11)$$

$$y_1(i) = yr(i) / \max(|yr|) \quad (12)$$

$$xr(i) = r(i) \cdot \sinh(\theta(i)) \quad (13)$$

$$yr(i) = r(i) \cdot \cosh(\theta(i)) \quad (14)$$

This leads to the equation for updating the position of a bald eagle feeding on prey:

$$P_{i,new} = rand \cdot P_{best} + x(i) \cdot (P_i - c_1 \cdot P_{mean}) + y_1(i) \cdot (P_i - c_2 \cdot P_{best}) \quad (15)$$

where  $c_1$  and  $c_2$  are both random numbers in the interval  $[1, 2]$  used to increase the intensity of the vulture's movement towards the optimum and centre points.

(4) Algorithm Pseudo-Code

According to the optimisation strategy of the BES algorithm, the pseudo-code of the BES algorithm is shown in Figure 5. During each iteration, an initial solution is randomly generated, and the final optimal solution is continuously obtained by evaluation with greedy selection strategy.

Algorithm 1: BES algorithm	
1	Initialize BES parameters, including population size, tmax;
2	Evaluate initial population and update best object with best value;
3	While t<=tmax do
4	for each point i do
5	Update position using select stage strategy, and calculate fitness;
6	Update best point;
7	Update position using search stage strategy, and calculate fitness;
8	Update best point;
9	Update position using swoop stage strategy, and calculate fitness;
10	Update best point;
11	end
12	t = t+1;
13	end
14	Output best solution.

**Figure 5** Flowchart of BES algorithm

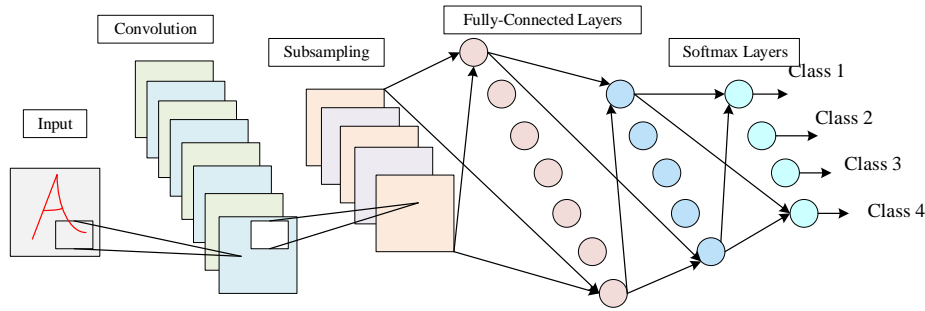


### 3.2. CNN networks

In order to construct an integrated APP design analysis model for health in and out of college physical education classes, this paper adopts convolutional neural network as the design analysis model construction algorithm to solve the APP design big data analysis problem [22].

Convolutional neural network (CNN) [23] is an artificial neural network that includes one or more convolution layers, i.e., at least one layer of neural network that uses convolution operations instead of the usual matrix multiplication operations. The structure of a CNN is shown in Figure 6. The convolution layer analyses each small

piece of the input sample more deeply to obtain features with a higher degree of abstraction; the pooling layer does not change the depth of the output of the previous layer, and can reduce the size of its matrix, thus achieving the purpose of reducing the parameters in the real neural network; the fully connected layer mainly completes the classification task, and obtains the scores of each category by weighted summation of the learned feature representations; the last layer of the general classification problem is the Softmax layer. Softmax layer is used to map the scores from the previous layer to the sample labelling space. The features of CNN include sparse connectivity, weight sharing and pooling.



**Figure 6** Structure of convolutional neural network

The convolution operation of a convolutional layer is defined as follows:

$$z_j^{(l)} = \sum_{i=1}^I w_i^{(l)} a_{i+j-1}^{(l-1)} + b^{(l)} \quad (16)$$

Where  $i$  is the index of the convolution kernel,  $l$  flag indicates the current convolution layer,  $l-1$  indicates the previous layer,  $I$  indicates the size of the convolution kernel.  $z_j^{(l)}$  denotes the feature value of the convolution layer after the convolution operation,  $w_i^{(l)}$  denotes the shared weights,  $a_{i+j-1}^{(l-1)}$  is the activation output value of the previous layer, and  $b^{(l)}$  is the bias of the convolution layer.

After going through each forward propagation calculation, the gradient of the loss function with respect to the weights and biases needs to be back propagated through the neural network. The optimisation algorithm used in this paper for weights and biases is the Adam optimisation algorithm.

### 4. A method for designing and analysing an integrated app for sports and health

#### data based on improved CNN network with BES algorithm

##### (1) Design of coding method

In order to improve the accuracy of APP design analysis of CNNs, the CNN parameters, i.e., network parameter weights and biases, are optimised using the BES algorithm.

##### (2) Adaptation function design

In order to improve the accuracy of CNN analysis, the root-mean-square error function is used as the objective function of the BES-CNN algorithm, which is calculated as follows:

$$\min RMSE = \sqrt{\left( \sum_{i=1}^M (\hat{y}_i - y_i)^2 \right) / M} \quad (17)$$

##### (3) Steps and Processes

The APP design analysis method based on the BES algorithm optimised CNN network for the integration of health data inside and outside the sports class mainly takes the APP design analysis features as input and the analysis values as output, and constructs the mapping relationship between the APP design analysis features and the design analysis values. The flowchart of the APP design analysis method based on BES-CNN algorithm for the integration of health data inside and outside the physical education class is shown in Figure 7. The specific steps are as follows:

Step 1: Construct the index system for designing and analysing the integrated APP for health data in and out of physical education classes under the background of "Internet+"; divide the data set into training set, validation set and testing set;

Step 2: The CNN network parameters are encoded using the BES algorithm, and the algorithm parameters such as population parameters and iteration times are initialised; the population is initialised and the objective function value is calculated;

Step 3: Update the population position according to the BES algorithm selection, search, and swoop predation phase strategy;

Step 4: Calculate the fitness value and update the optimal solution;

Step 5: Determine whether the termination condition is satisfied, if so, exit the iteration, output the CN network parameters, and execute step 3, otherwise continue to execute step 6;

Step 6: Decode the optimised CNN network parameters based on the BES algorithm, obtain the optimal convolutional neural network parameters, and construct the integrated APP design and analysis model based on the BES-CNN algorithm for physical education inside and outside the classroom under the background of "Internet+";

Step 7: Test and analyse the current test set using the trained APP design analysis model and output the corresponding test results.

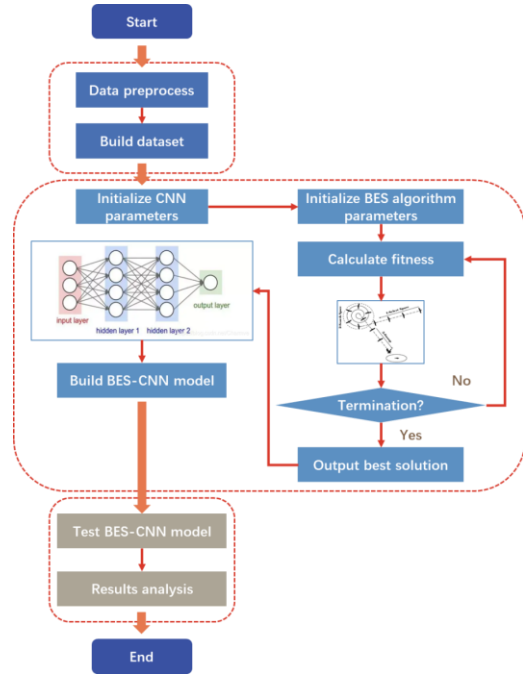


Figure 7 APP design analysis method based on BES-CNN

### 5. Experiments and analysis of results

In order to verify the advantages and disadvantages of the integrated APP design and analysis method of health data inside and outside the physical education class under the background of "Internet+" proposed in this paper, four analysis methods are selected for comparison, and the specific parameters of each algorithm are set as in Table 1. The experimental simulation environment is Windows 10, with a CPU of 2.80GHz, 8GB of RAM, and the programming language Matlab2021a.

Table 1 Parameter settings for the design and analysis method of the integrated APP for health data in and out of physical education classes in the context of "Internet Plus"

arithmetic	parameterisation
CNN	The number of nodes in the hidden layer of the CNN network is given by the following analysis, using Adam's technique to optimise network training
GWO-CNN	The control parameter a of GWO is decreasing from 2 to 0, and the number of GWO populations is the same as the CNN network nodes set at BES-CNN
HHO-CNN	HHO algorithm E0 = 2, the number of HHO populations is the same as the CNN network nodes set at BES-CNN
FTTA-CNN	FTTA algorithm Pcomm=0.2, Pstudy=0.2, Perror=0.001, number of FTTA populations and CNN network nodes are set at the same level as BES-CNN
BES-CNN	BES is a parameter-free optimisation algorithm, and an analysis of the number of BES populations and CNN network nodes yields

(1) Analysis of the effect of population size and the number of CNN hidden layer nodes

In order to analyse the impact of the population size of BES algorithm and the number of hidden layer nodes of CNN network on the APP design and analysis method, this

paper compares and analyses the performance of the APP design and analysis method of integrating internal and external health data of physical education classes in the background of "Internet+" under the conditions of different population sizes and different numbers of CNN hidden layer nodes. Figures 8 and 9 show the influence of different population sizes and the number of CNN hidden layer nodes on the accuracy and time of the APP analysis method.

As can be seen from Figure 8, with the increase of the number of BES algorithm populations, the precision of the analysis value of the integrated APP design of internal and external health data in physical education classes in the context of "Internet+" increases gradually; with the increase of the number of CNN nodes, the RMSE of the analysis value of the integrated APP design of internal and external health data in the context of "Internet+" becomes smaller and the precision increases. As the number of CNN nodes increases, the RMSE of the analysis value of the integrated APP design for internal and external health data in physical

education class under the background of "Internet+" becomes smaller and the precision increases. As can be seen from Figure 9, with the increase in the number of populations of the BES optimisation algorithm, the analysis time of the integrated APP design of internal and external health data in physical education classes under the background of "Internet+" gradually increases; with the increase in the number of hidden layer nodes of the CNN network, the analysis time of the integrated APP design of internal and external health data in physical education classes under the background of "Internet+" gradually increases. With the increase of hidden layer nodes of CNN network, the analysis time of the integrated APP design of health data inside and outside the physical education class under the background of "Internet+" increases. In summary, by considering the balance between accuracy and time performance, the intelligent optimisation algorithm selected in this paper has a population size of 60 and 100 CNN hidden layer nodes.

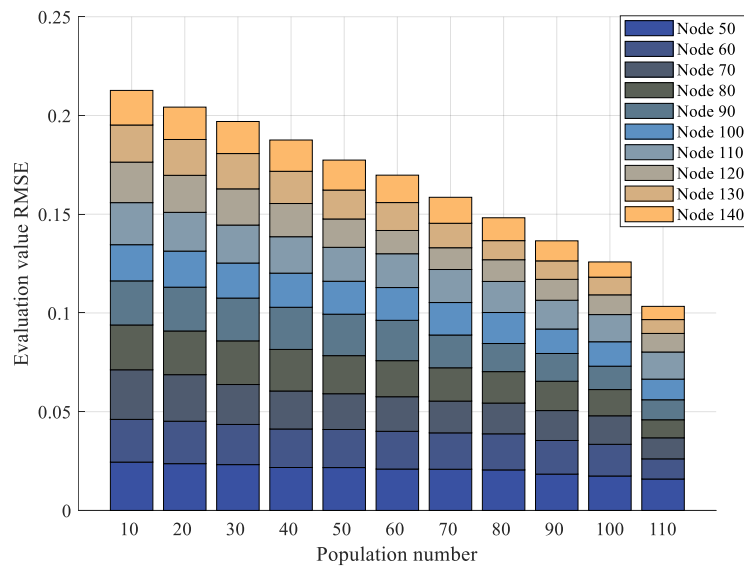
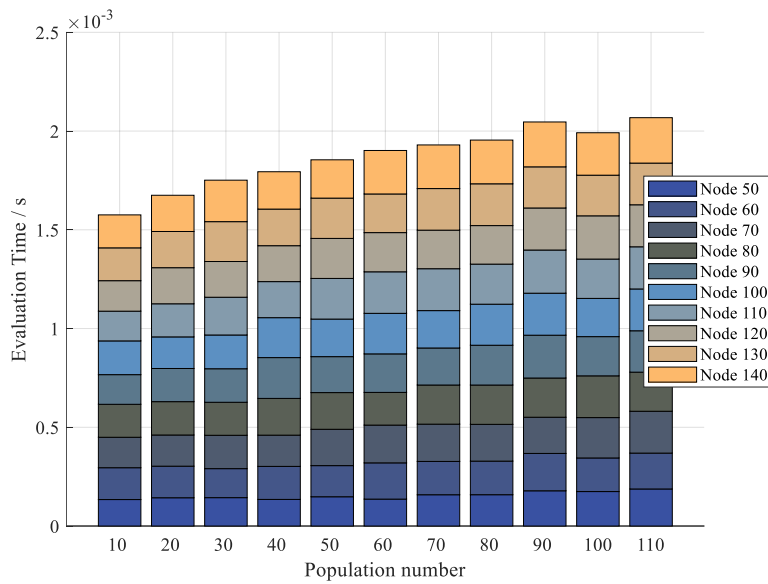


Figure 8 Analysis accuracy for different population sizes and number of CNN hidden layer nodes





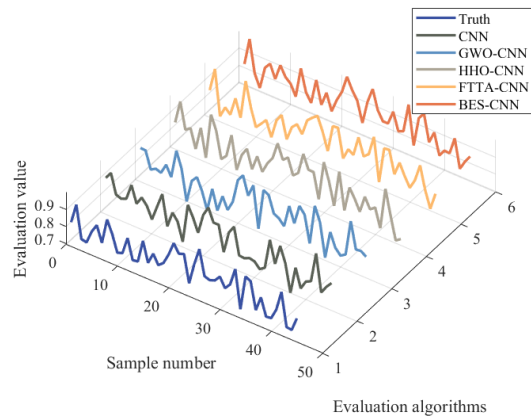
**Figure 9** Analysis time for different population sizes and number of CNN hidden layer nodes

(2) Comparison of results of APP design analysis methods

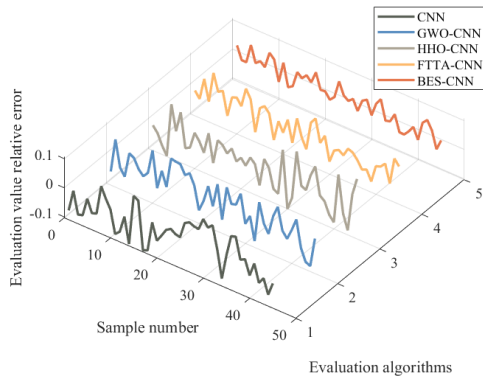
In order to verify the effectiveness and superiority of the integrated APP design and analysis method based on BES-CNN algorithm for health data inside and outside physical education classes in the context of "Internet+", the integrated APP design and analysis method based on BES-CNN algorithm for health data inside and outside physical education classes in the context of "Internet+" was compared with that based on CNN, GWO-CNN, HHO-CNN, FTFA-CNN algorithm. The effectiveness and superiority of the APP design and analysis method for integrating health data in and out of physical education classes under the background of "Internet+" is compared with the APP design and analysis method for integrating health data in and out of physical education classes based on BES-CNN algorithm and CNN, GWO-CNN, HHO-CNN and FTFA-CNN algorithms, and the performance results of the models are shown in Figs. 10, 11, and 12.

Figures 10 and 11 show the analysed values and relative errors of the APP design based on each algorithm for the integration of health data in and out of physical education classes in the context of "Internet+". As can be seen from Figure 10, the analytical value of APP design based on BES-CNN algorithm is the closest to the true value; the analytical value of APP design based on other algorithms for the integration of health data in and out of physical education classes under the background of "Internet+" has the same development trend as the true value, which shows that the APP design analysis model based on machine learning algorithms can predict the change trend of the analytical value. This shows that the APP design analysis model based on machine learning algorithms can predict the trend of the analysis value. As can be seen from Figure 11, the relative error between the APP design analysis value and the true value based on the

BES-CNN algorithm is the smallest, which is controlled within 0.017, and the remaining algorithms are FTFA-CNN, GWO-CNN, HHO-CNN, and CNN, with the error ranges of 0.02, 0.05, 0.09, and 0.12, respectively. prediction accuracy of the analysed values, the prediction accuracy of APP design analysis based on BES-CNN algorithm is better than other algorithms.

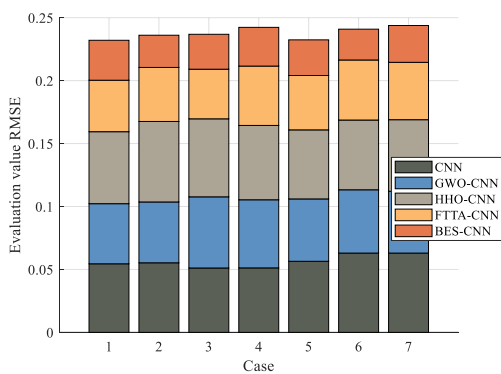


**Figure 10** Analysis of the design of the integrated APP based on algorithms for health data inside and outside the physical education classroom in the context of "Internet+".

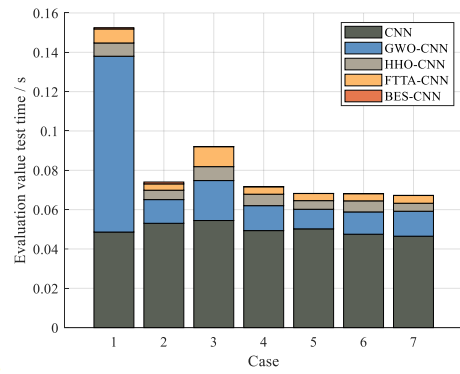


**Figure 11** Relative error results of analysed and true values based on each algorithm

Figure 12 gives the analysis time of the APP design based on each algorithm for the integration of health data inside and outside the physical education class under the background of "Internet+" under different working conditions. As can be seen from Figure 12, the RMSE rankings of the algorithms under different working conditions are BES-CNN, FTTA-CNN, GWO-CNN, HHO-CNN, and CNN; the performance of the algorithms under different working conditions is relatively stable, which indicates that the robustness of the prediction errors of the algorithms in the APP design and analysis is better; the rankings of the algorithms' analysis times under different working conditions are, in order, BES-CNN, FTTA-CNN, HHO-CNN, HHO-CNN, HHO-CNN and CNN. BES-CNN, FTTA-CNN, HHO-CNN, GWO-CNN, CNN; under different working conditions, the prediction time performance of each algorithm is relatively stable, thus indicating that the robustness of APP design analysis prediction time of each algorithm is better.



(a) RNN



(b) DSO-RNN

**Figure 12** Time for analysing the design of the APP for integrating health data in and out of physical education classes in the context of "Internet Plus"

## 6. Conclusion

With the development of computer technology and Internet technology, the national wisdom of sports is clearly put forward, and the concept of Internet + sports is more favourable to the health management of college students. Aiming at the current problem of low precision and insufficient objective evaluation of the APP design analysis method for the integration of health data inside and outside of physical education classes, this paper integrates the bald eagle optimization algorithm with convolutional neural network to construct the BES-CNN design analysis model and carry out the APP design analysis with the user behaviour data of the APP integration of health data inside and outside of physical education classes under the conditions of the Internet. The method analyses the design framework of the integrated APP of health data inside and outside physical education classes under Internet conditions, extracts the APP design analysis indexes, constructs the design analysis index system of the integrated APP of health data inside and outside physical education classes in the university, combines the BES and CNN, and puts forward the APP design analysis method of the integrated APP of health data inside and outside physical education classes based on the BES-CNN algorithm. The analysis effect between the BES-CNN analysis model and the other four models is compared, and the difference in the model analysis effect of the test samples is evaluated. The results show that the prediction accuracy of APP design analysis based on BES-CNN algorithm is better than the other algorithms; the APP design analysis prediction time robustness of each algorithm is better.

In this paper, the selection of influencing factors in the model is not pre-processed and analysed, which consumes too much time and energy. In the future, principal component analysis can be introduced for feature selection to further improve the analysis efficiency of the model.

## Acknowledgements.

This work was supported by 2023 National Social Science Foundation project (23BTY088) : Research on heritage assessment and mechanism Innovation of Beijing 2022 Winter Olympic Games. Jining University Curriculum Ideological and Political Demonstration Course Project (SZ202307)

## References

- [1] Systems M .Retracted: Design of Hybrid Teaching System for Aerobic Exercise Class of Recreational Sports Major[J].Mobile Information Systems,. 2023.
- [2] Ahmed S , Gomersall S , Khan A .Trends and determinants of organised sports participation in immigrant and Australian children: a nine-year follow-up .[J].Journal of science and medicine in sport, 2022.
- [3] Barandela J S , Barajas A , Sanchez-Fernandez P .Implications for tourism management of including uncertainty in the estimation of the economic impact of sports events[J].Sport, Business and Management: an International Journal, 2023, 13(2):181-194.
- [4] Mohamed S .Effect of Some Fabric Structure on the Functional Properties of Sports Clothing Fabrics[J].Journal of Design Sciences and Applied Arts,. 2022.
- [5] Tunsoiu N ,Cristian-Vasile D, Mihaela-Elena U, Dugeescu I, Maria-Critina T. Electronic System Design for a Bespoke Sports Training Equipment[J]. Macromolecular symposia, 2023(1):411.
- [6] Plahutina A .Modeling of the life cycle of a sports complex building at the stage of design, operation and reconstruction[J]. Architecture, 2023.
- [7] hristian R G , Sarofim S N , Gordon B S ,et al. You're getting warmer: examining a "warmth effect" as antecedent to cause-related purchase intentions for sport-themed CRM[J].Journal of consumer marketing, 2022.
- [8] Nie B , Zhou T .Design of Sports Training Improvement and Evaluation Method under the Background of Big Data[J].Advances in multimedia, 2022(Pt.7). 2022.
- [9] Li F , Zhang S , Cheng W .Application and Optimization of Wing Structure Design of DF-2 Light Sports Aircraft Based on Composite Material Characteristics[J].Journal of nanomaterials, 2022(Pt.5):2022.
- [10] Verner-Filion J , Gaudreau P .Need satisfaction and Sport motivation predict selection in a competitive Youth Soccer Team over and above the relative age effect[J].International journal of sport psychology, 2023(3):54.
- [11] Chen Y , Hu H .Design and Research of the AI Badminton Model Based on the Deep Learning Neural Network[J].
- [12] Ylmaz E , Ndoan Z , Kl A E .Investigation of the cosmetic effects of pattern design and wearability in sports bras[J].International journal of clothing science and technology, 2023.
- [13] Meltzer L M , Leasure C S , Dyce J ,et al. Case factors for selection of femoral component type in canine hip arthroplasty using a modular system[J]. Veterinary Surgery, 2022, 51(2):286-295.
- [14] Peng Y .Study on the Path of Building a Sports and Leisure Town with 10,000 Mu Ecological Tea Garden in Western Hunan under the Background of Rural Revitalisation[J].Modern Economics & Management Forum, 2022, 3(1):1-5.
- [15] Appukutty M , Shyam S , Choo Z Y , Tan S S , Chong H Z M , Choong A. Effects of n-3 long-chain polyunsaturated fatty acid supplementation on the omega-3 index , and exercise performance among Malaysian football players: a randomised controlled trial[J].British food journal, 2023.
- [16] Kim B G .The Effect of Sportswear Customer "s Lifestyle on Design Preference through Purchase Criteria[J].Korean Journal of Sports Science, 2022.
- [17] Maciel D G , Cerqueira M S , Gabbett T J , Elsangedy H M , Vieira W H D B. Should We Trust Perceived Effort for Loading Control and Resistance Exercise Prescription After ACL Reconstruction?[J].Sports health, 2022.
- [18] Fakfare P , Manosuthi N .Examining the influential components of tourists' intention to use travel apps: the importance-performance map analysis[J].Journal of Hospitality and Tourism Insights, 2023, 6(3):1144-1168.
- [19] Zhang H P , Kang J .A Study on the Sports Clothing Specialised Store with Interactive Application: focusing on the impact on consumers' willingness to buy[J].Korea Institute of Design Research Society, 2023.
- [20] Alsattar H A , Zaidan A A , Zaida B B. Novel meta-heuristic bald eagle search optimisation algorithm[J]. Artificial Intelligence Review, 2020, 53(3): 2237-2264.
- [21] Peiwen Zhao, Damin Zhang, Lina Zhang, Chengcheng Zou. A vulture search algorithm incorporating the golden sine algorithm and vertical and horizontal crossover strategies[J]. Computer Applications, 2023, 43(1): 192-201.
- [22] SHAN Hyun-Yang, SUN Zhan-Li, ZENG Zhi-Gang.RFNet:Convolutional neural network for 3D point cloud classification[J]. Journal of Automation, 2023, 49(11):2350-2359.
- [23] Yang Jun,Zhang Chen. Semantic segmentation of 3D point cloud by fusing dual attention mechanism and dynamic graph convolutional neural network[J]. Journal of Beijing University of Aeronautics and Astronautics, 2023, 48.