

On the optimal user grouping in NOMA system technology★

Antonino Masaracchia^{1,*}, Dac-Binh Ha², Ngoc-Phuc Le²

¹Queens University Belfast, Belfast BT7 1NN, UK

²Duy Tan University, Da Nang, Vietnam

Abstract

This paper provides a state-of-art analysis of the most relevant studies on optimal user-aggregation strategies for non-orthogonal multiple access (NOMA) technology. The main ideas behind are *i*) to highlight how, in addition to the adoption of an optimal power allocation scheme, an optimal user-aggregation strategy represents an important key factor for improving NOMA system performance, and *ii*) to provide an exhaustive survey of the most relevant studies which can serve as useful starting point for the definition of new channel state-aware user-aggregation strategies for NOMA systems which, at the time of writing, represents a research field that still remains to be investigated more in depth. A detailed and complete analysis, which permits to point out the need to guarantee a certain relationship between users' channel gain, is provided for each cited work.

Received on 27 June 2019; accepted on 14 July 2019; published on XXXX

Keywords: Algorithms and Protocols, Communication networks, Intelligent systems, Optimization, Survey and review

Copyright © 2019 Antonino Masaracchia *et al.*, licensed to EAI. This is an open access article distributed under the terms of the Creative Commons Attribution license (<http://creativecommons.org/licenses/by/3.0/>), which permits unlimited use, distribution and reproduction in any medium so long as the original work is properly cited.

doi:10.4108/XX.X.X.XX

1. Introduction

Nowadays, the ever-increasing diffusion of powerful multimedia devices, such as smartphones and tablets, as well as the rapid development of the mobile Internet and the Internet of Things (IoT), are drastically accelerating the demand of new high data-rate and low latency applications. In addition, a scenario in which seven trillions of wireless devices will serve seven billions of people, sharing the even more scarce physical resources and generating 49 exabytes of global mobile data traffic per month, has been envisioned for the next future [1, 2]. Then, the development of a new wireless communication technology, referred to as fifth generation (5G) network, represents a necessary step in order to cope with all these upcoming events that can cause the collapse of the actual cellular network

infrastructure [3]. Indeed, respect to the actual 4G network, the 5G wireless communication system will be able to achieve *i*) from 10 up to 100× higher typical user-data rate, *ii*) 1000× higher mobile data volume per geographical area, *iii*) from 10 up to 100× more connected devices, and *iv*) sub-millisecond level end-to-end latency [4]. In order to meet all these requirements, the design of a new efficient, scalable and flexible air-interface, which includes different modules of both physical (PHY) layer and medium access control (MAC) layer, represents a crucial aspect for the next generation wireless network infrastructure.

Generally, a wireless communication network embeds a radio access technology (RAT) which, employing multiple access techniques, provides multiple mobile terminals with a connection to the core network. Accordingly with its basic principle, a multiple access technique can be classified as [5]: *i*) orthogonal multiple access (OMA) technique, or *ii*) non-orthogonal multiple access (NOMA) technique.

OMA schemes allow each user to entirely separate unwanted signals from the desired signal by allocating different orthogonal resource (time/frequency/code) block (RB) to each user. Examples of these multiple

★This research was funded by Vietnam National Foundation for Science and Technology Development (NAFOSTED) under Grant No. 102.04-2017.301.

*Corresponding author. Email: A.Masaracchia@qub.ac.uk

Antonino Masaracchia is with the School of Electronics, Electrical Engineering and Computer Science, Queens University Belfast, Belfast BT3 9DT, U.K

access techniques are frequency division multiple access (FDMA), time division multiple access (TDMA), code division multiple access (CDMA), and orthogonal frequency-division multiple access (OFDMA).

In contrast to OMA, NOMA schemes allow to allocate one RB to multiple users at the same time within the same cell, offering a number of advantages, like spectrum efficiency and fairness among base station (BS)-close and edge users, which permit to label NOMA as a promising multiple access scheme for future radio access technology [6–8]. Nowadays, there exist different NOMA solutions which, how illustrated in Fig. 1, can broadly be categorized in two classes [7]: *i*) code-domain NOMA (C-NOMA), and *ii*) power-domain NOMA (P-NOMA).

Like the basic CDMA systems, in C-NOMA systems the entire available RB is shared among all users. The main difference consists in using user-specific spreading sequences that are either sparse sequences or non-orthogonal crosscorrelation sequences of low correlation coefficient. Low-density spreading CDMA (LSD-CDMA) [9], low-density spreading-based OFDM (LDS-OFDM) [10], and sparse code multiple access (SCMA) [11] are examples of C-NOMA multiple access techniques.

In contrast to C-NOMA, the basic idea of P-NOMA is to serve multiple users in the same RB multiplexing in power domain. This is possible through power-domain superposition coding (SC) multiplexing at transmitter and successive interference cancellation (SIC) at receiver [12, 13]. As illustrated in Fig. 2, a BS which serves N users, within its coverage area, transmits a linear superposition of N users' data by allocating a fraction β_i of the total available power P to each user, i.e., the power allocated for the i_{th} user is $P_i = \beta_i P$. Then, each user is able to decode its own data by deleting the interfering users' signals through the SIC principle.

Finally, there exist some other multiple access techniques which are also closely-related to NOMA. These are represented by pattern division multiple access (PDMA) techniques [14] and spatial division multiple access (SDMA) techniques [15]. In PDMA systems, the transmitter firstly maximizes the diversity and minimizes the overlaps among multiple users in order to design non-orthogonal patterns. Secondly, the multiplexing is performed either in the code domain, spatial domain, or a combination of them. The working principle of SDMA is inspired by basic CDMA systems. However, instead of using user-specific spreading sequences, SDMA distinguishes different users by using user-specific channel impulse responses (CIRs). Then, accurate CIR estimators are necessary for a successful decoding.

As regards the P-NOMA, the performance of these systems strongly depend on the adopted power allocation scheme. Indeed, based on users' channel conditions, the transmitter needs to carefully choose the proper amount of power, which should be assigned to each user, in order to satisfy network service requirements, i.e., Quality-of-Service (QoS), user-perceived data throughput and maximum throughput. Owing to this fact, several studies have been conducted in order to propose power allocation schemes, aiming to optimize some network metrics [16–26]. Most of these contemporary studies on power allocation for NOMA systems can broadly be divided into two main classes: *i*) single-channel analysis and *ii*) multiple-channel analysis. In the first case, optimal power allocation schemes are derived supposing that all N users are multiplexed into power domain within the same RB [17–19]. In the second case, the available bandwidth is divided into different *independent* RBs, multiplexing a subset of users on each RB [16, 20, 21].

In addition to the usage of the optimal power allocation scheme, recently has been shown in [27] how the user aggregation process and user to sub-band pairing represent other important aspects for the performance of NOMA systems. In particular, has been illustrated how, respect to the conventional OMA systems, the performances of a fixed power allocation NOMA (F-NOMA) can be further enlarged by multiplexing users carefully, accordingly to their channel condition.

Generally the optimization problems for user-aggregation and user to sub-band pairing in NOMA systems are represented by a mixed integer-linear problem (MILP) which, even if small, can result difficult to solve. Under this perspective, this paper provides a state-of-art analysis of user-aggregation strategies for P-NOMA systems which, at the time of writing, represent the most relevant approaches published in literature.

The rest of the paper is organized as follow. The system model and a MILP problem for user aggregation in P-NOMA systems are presented in Section 2. the analysis of the actual state of the art on user aggregation and sub-band pairing is presented in Section 3. Finally, conclusions are provided in Section 4.

2. P-NOMA system model

This section provides either a system model for the analysis of the critical aspects of user-aggregation and sub-band mapping in P-NOMA systems, and the formulation of an optimization problem which highlights how the user-aggregation impacts on transmitting power requirement.

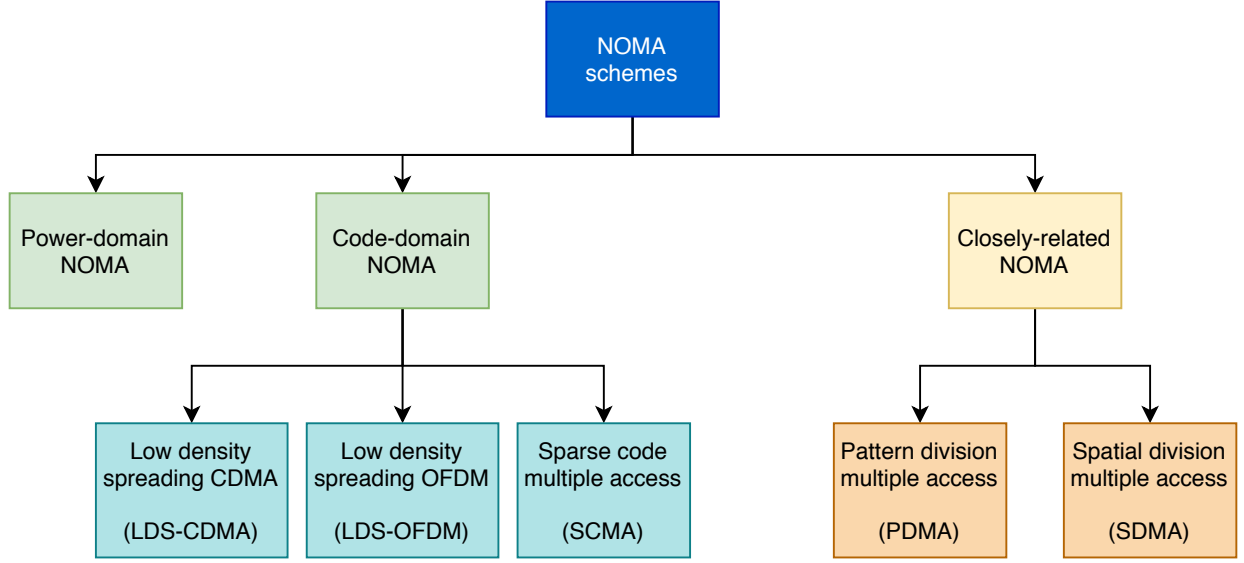

Figure 1. Classification of NOMA techniques.

2.1. Preliminaries

Without loss of generality, suppose that a single-antenna transmitter serves N single-antenna users located within its coverage area and undergoing a channel \mathcal{H} . In addition, suppose that the available bandwidth B is divided into M sub-bands, each of them used to multiplex an amount of user N_j , with the constraint $\sum_{j=1}^M N_j = N$. According with the SC multiplexing, supposing that each user is multiplexed into a single sub-band, the signal received by user i along the sub-band j can be expresses as:

$$y_{i,j} = h_{i,j} \times x_j + w_j, \quad (1)$$

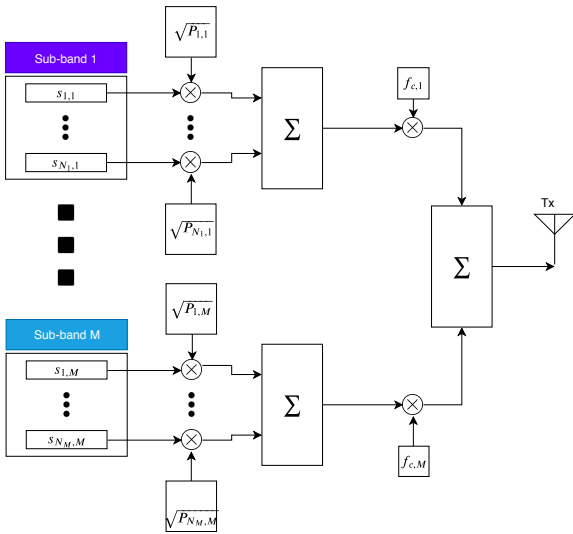

Figure 2. General P-NOMA transmitter scheme.

where $x_j = \sum_{i=1}^{N_j} \sqrt{P\beta_{i,j}} S_{i,j}$ is the superimposed signal transmitted over the sub-band j , with $\sum_{j=1}^M \sum_{i=1}^{N_j} \beta_{i,j} = 1$, $h_{i,j}$ denotes the channel coefficient of user i along the sub-band j , and w_j represents the noise term with spectral density σ_j^2 . The information $S_{i,j}$ is transmitted with a power level $P\beta_{i,j}$ to user i along sub-band j . Supposing that channel coefficients are ordered in a ascending manner within each sub-band, i.e., $0 < |h_{1,j}|^2 \leq |h_{2,j}|^2 \dots \leq |h_{N_j,j}|^2$, each user, except the one with worst channel condition, implements the SIC iteratively, decoding signals transmitted to users with weaker channel conditions firstly and subtracting them from superimposed received signal. The signal obtained through that subtracting process is used to decoding its own related message. At this step, signals associated to users with better channel conditions, are considered as additive noise. Taking that into account and supposing that $\|S_{i,j}\|^2 = 1$, the downlink achievable rate for user i within the sub-band j can be expressed as [28]:

$$R_{i,j} = \log_2 \left(1 + \frac{\beta_{i,j} P |h_{i,j}|^2}{P |h_{i,j}|^2 \sum_{k=i+1}^{N_j} \beta_{k,j} + \sigma_j^2} \right). \quad (2)$$

2.2. The impact of user aggregation

This subsection provides an example on how the system performance of NOMA systems are influenced by the adopted user aggregation strategy. In particular, without a loss of generality, it is analysed the impact on power requirement at BS. In addition, the optimization problem for minimum power requirements is formulated.

From (2), in order to guarantee a minimum QoS to user i multiplexed into sub-band j , i.e., $R_{i,j} \geq R_{i,j}^{min}$,

the minimum amount of power $P_{i,j}^{min}$ which must be allocated to that user can be formulated as:

$$P_{i,j}^{min} \geq A_{i,j} \times \left(\sum_{k=i+1}^{N_j} P_{k,j} + \frac{\sigma_j^2}{|h_{i,j}|^2} \right), \quad (3)$$

in which $P_{i,j} = P\beta_{i,j}$ and $A_{i,j} = \left(2^{R_{i,j}^{min}} - 1\right)$. Considering the user with the best channel condition, and supposing that all the users have the same QoS requirements, i.e., $A_{N_j,j} = A_{N_j-1,j} = \dots = A_{1,j} = A$, Eq. (3) can be written as:

$$P_{i,j}^{min} \geq \begin{cases} A \times \frac{\sigma_j^2}{|h_{N_j,j}|^2} = P_{N_j,j}^{min} & i = N_j ; \\ A \times \left(\sum_{k=i+1}^{N_j} P_{k,j} + \frac{\sigma_j^2}{|h_{i,j}|^2} \right) & i < N_j ; \end{cases} \quad (4)$$

After some mathematical manipulations, the second case can be re-expressed as:

$$P_{i,j}^{min} \geq A \times P_{N_j,j}^{min} + A \times \sum_{k=i+1}^{N_j-1} P_{k,j} + P_{N_j,j}^{min} \times \frac{|h_{N_j,j}|^2}{|h_{i,j}|^2} \quad (5)$$

Then, the total amount of power required in order to guarantee the QoS of all users into sub-band j is :

$$P_j^{tot} = \sum_{i=1}^{N_j} P_{i,j}^{min} \geq \sum_{i=1}^{N_j-1} A \times P_{N_j,j}^{min} + A \times \sum_{i=1}^{N_j-1} \sum_{k=i+1}^{N_j-1} P_{k,j} + P_{N_j,j}^{min} \times \sum_{i=1}^{N_j-1} \frac{|h_{N_j,j}|^2}{|h_{i,j}|^2} + P_{N_j,j}^{min}. \quad (6)$$

Now, grouping by common factors and observing that the first term is independent of index i , the following expression is attained:

$$P_j^{tot} \geq P_{N_j,j}^{min} \times \left((N_j - 1)A + 1 + \sum_{i=1}^{N_j-1} \frac{|h_{N_j,j}|^2}{|h_{i,j}|^2} \right) + A \times \sum_{i=1}^{N_j-1} \sum_{k=i+1}^{N_j-1} P_{k,j}. \quad (7)$$

Then, the total power over the whole bandwidth is given by:

$$P_{tot} = \sum_{j=1}^M P_j^{tot}. \quad (8)$$

This represents the minimum amount of power which is necessary to use for guaranteeing the QoS of all

users multiplexed into different sub-channels, within the same bandwidth. As can be seen from (7), this amount of energy strongly depends on channel gain and QoS constraint of multiplexed users. Let $\mathbf{U} \in \{0; 1\}^{N \times M}$ the sparse matrix in which each element $u_{i,j}$ is equal to 1 if user i is allocated to sub-carrier j and 0 otherwise. Then, the optimization problem for minimum power requirement can be formulated as:

$$\min_{\mathbf{U}} P_{tot}; \quad (9a)$$

$$\text{s.t. } R_{i,j} \geq R_{i,j}^{min}, \quad \forall i = 1 \dots N; \forall j = 1 \dots M \quad (9b)$$

$$\sum_{j=1}^M u_{i,j} = 1, \quad \forall i = 1 \dots N; \quad (9c)$$

where the constraint (9b) represents the minimum QoS requirement of each user, while the constraint (9c) ensures that the each user will be multiplexed only into one sub-carrier.

3. User-aggregation strategies

From the analysis conducted in the previous section, one can note how the user aggregation problem, due to its structure, is usually represented by a MILP optimization problem which, even if small, can result difficult to solve. Then, several heuristic approaches have been proposed in order to address the user aggregation and sub-band mapping in P-NOMA systems.

3.1. State of the art.

In [27], the impact of user pairing on the performance of two NOMA systems, i.e., F-NOMA and cognitive-radio-inspired NOMA (CR-NOMA), has been studied. Both analytical and numerical results have been provided to demonstrate that F-NOMA can offer a larger sum rate than OMA. Moreover, has been illustrated how the performance gain of F-NOMA over conventional OMA can be further enlarged by selecting users whose channel conditions are more distinctive within the same sub-band. Since NOMA can be also viewed as a special case of cognitive radio systems, in which a user with a strong channel condition (secondary user) is squeezed into the spectrum occupied by a user with a poor channel condition (primary user), authors also highlighted how the channel quality of the user with a poor channel condition is critical in order to guarantee an outage probability of the user with better channel conditions. Subsequently, in [29] they proposed a matching theory based strategy for user pairing in CR-NOMA systems.

A two-steps proportional fairness-based user pairing and power allocation for NOMA has been proposed in [30]. It was considered a scenario in which two

users at most were allocated along each available sub-band. Under this perspective a mathematical analysis was performed in order to highlight how the channel coefficients, of users within the same sub-band, impact on either power coefficients and the fairness among users. However, no explicit procedure on how users should be aggregated was provided. They only provided a closed form expression which, knowing the channel conditions of each user in a pair, permits to calculate the power coefficients which maximize the user fairness.

A channel state sorting pairing algorithm (CSS-PA) was proposed in [31]. A set of N users is ordered in ascending order according with their channel gains, i.e., $|h_1|^2 \geq |h_2|^2 \geq \dots \geq |h_N|^2 \geq 0$. After that, the pairing process is performed according with binary dislocation principle (BDP). This means that the first user is paired with the $N/2$ th user, the second user with the $(N/2 + 1)$ th user, keeping pairing like this until no candidate user is left. They shown how the adoption of this pairing approach provides an average channel capacity higher than other pairing approaches, like random pairing (RPA), orthogonal pairing algorithm (OPA) and determinant pairing algorithm. A similar approach has been proposed also in [32] for the case of multiple-input multiple-output (MIMO) transmission.

Authors in [33] examined a joint user pairing and dynamic power allocation (JUPDPA) design to maximize the energy efficiency (EE) in the multi-cell MIMO-NOMA downlink system. A set of K users are ordered in the descending order based on the Euclidean norm of their channel vectors, i.e., $\|h_i\|$, and divided in two groups, named cell centre (CC) and cell edge (CE), depending if their channel vector norm is higher or lower than the median value defined in (10), respectively. Odd users from the CC group select the least difference Euclidean norm user from the CE group and even users from the CC group choose the CE user which has the large difference in the Euclidean norm between them. A similar approach has been proposed in [34]. In both cases the aim of user grouping is to maximize the sum-rate.

$$M = \frac{\|h_{\frac{K}{2}}\| + \|h_{\frac{K}{2}+1}\|}{2}. \quad (10)$$

A fast and efficient user pairing algorithm has been proposed in [35]. It is considered a scenario in which at most two users are multiplexed along each sub-channel. This algorithm consists of two nested iterative steps. In the outer loop, the user and the RB which maximize the proportional fairness function over the unallocated RB are identified. Then, in the inner loop, the second user to be multiplexed with the first user, previously identified in the outer loop, is determined on order to maximize the sum of proportional fair (PF) metrics of the paired users. They shown how this algorithms reaches the same cell throughput obtained with an

exhaustive search procedure, but employing an amount of processing time which is eight time lesser.

In [36], another interesting analysis which highlights the importance of the user pairing has been presented. Under this perspective, the authors outlined how users with small difference in channel gain should not be multiplexed within the same sub-channel. Then, a virtual NOMA user aggregation scheme was proposed. In particular, considering a bandwidth B and three users with channel coefficients ordered as $|h_3|^2 \geq |h_2|^2 \approx |h_1|^2$, the message to user 3 is transmitted over the whole bandwidth, while messages to users 1 and 2 are superimposed to signal 3 but along independent sub-bands. It was shown how this approach provides better performance respect to either OMA and conventional NOMA. A similar approach has been also proposed in [37]. The principle is the same, but in this case the whole bandwidth is allocated to the user with worst channel condition and users with good channel conditions are multiplexed with it into independent sub-bands.

Inspired by works presented in [36, 37], a time sharing based approach to accommodate similar gain users in NOMA systems has been proposed in [38]. In particular, considering a bandwidth B and three users with channel coefficients ordered as $|h_3|^2 \geq |h_2|^2 \approx |h_1|^2$, they divide the total transmission time duration in two time slots named t_1 and t_2 , respectively. In the first time slot t_1 , UE 3 is paired with UE2 over the complete bandwidth, where $t_1 = \alpha$, such that $0 \leq \alpha \leq 1$. For the remaining time $t_2 = 1 - \alpha$, UE 3 and UE 1 are paired with each other over the total bandwidth B . Also in this case they shown how this approach provides better performance in system throughput than the conventional NOMA. In addition it reduces the time for SIC implementation at receiver.

In [39], the users are paired and selected to maximize the weighted sum rate of a multi-antenna system using the greedy-search based method. In particular, a correlation threshold ρ is firstly defined. Secondly, indicating with h_i and h_j the channel gain vectors of user i and j , respectively, a set of users which respect condition (11) is defined

$$\frac{\|h_i^H h_j\|}{\|h_i\| \|h_j\|} \geq \rho. \quad (11)$$

In other words this set contains all users which have a strong correlation. Finally, users of this set are paired in order to maximize the sum rate of the network. Users outside this set are multiplexed with a conventional OMA scheme.

The adoption of neighbourhood search algorithms, like the hill climbing and simulated annealing algorithm, for user pairing systems has been investigated in [40]. Also in this case they shown how the downlink

sum-throughput of a NOMA system can be improved grouping users properly.

A low complexity game theory-based algorithm for user clustering, and a closed-form solution for power allocation, aiming to maximize the cell sum-rate, were proposed in [21]. It was considered a downlink mm-wave-NOMA scenario with one BS and N users, equipped with N_t and N_r antennas, respectively. These users are supposed to be organized into K clusters, each with a cluster-head (CH) node.

A particle swarm optimization (PSO)-Based approach for user-pairing in NOMA systems has been proposed in [28]. In particular, authors provided an exhaustive analysis of a PSO-based configuration applied to NOMA systems in order to perform user aggregation along different sub-channels. The idea behind is to highlight the main characteristics of this PSO-based configuration for understanding how this policy enables the transmitter to require the minimum downlink transmitting power, while guaranteeing the quality of service (QoS) constraint of each user.

3.2. Discussion

From the analysis conducted in the previous subsection, most of the contemporary studies on user aggregation for NOMA systems can broadly be divided in two main classes: *i*) fairness maximization, and *ii*) sum rate maximization. Indeed, from these studies is possible to note how the user aggregation scheme mainly impacts on these aspects. The adoption of an optimal user grouping strategy in NOMA systems can reduce the probability that one or more users multiplexed within the same RB are not able to decode their data correctly, affecting negatively either fairness and sum-rate throughput, which can result lower than the ones reached through a OMA technology. Despite the differences between these works, one can observe how the relation between channel gains experienced by each users is always outlined as a key factor for the development of an optimal user aggregation policy.

4. Conclusion

In this paper, the importance of using an optimal user-aggregation scheme in NOMA systems has been highlighted. In particular, for a better understanding and without a loss of generality, an optimization problem has been formulated in order to show how the power requirement at the transmitter side strongly depends from the channel gain of aggregated users. Usually, these are MILP problems which, even if small, are difficult to solve and an exhaustive can result to be not efficient. Under this perspective, an exhaustive review about the most relevant contemporary works for user aggregation strategies is provided. For each work a detailed analysis has been provided pointing

out the most relevant characteristics. From this analysis, one can note how *i*) the user aggregation mainly impact on the cell sum-rate and on the fairness among users, *ii*) a particular relationship between users' channel gains should be respected in order to reach an optimal configuration, i.e., euclidean distance and/or correlation between channel gains. However, this research field still remains to be investigated more in depth. Then, this paper can serve as starting point for the investigation and design of new efficient and scalable channel state-aware user aggregation policy for NOMA systems.

References

- [1] DAVID, K., DIXIT, D. and JEFFERIES, N. (2010) 2020 Vision. *IEEE Vehicular Technology Magazine* 5(3): 22–29. doi:10.1109/MVT.2010.938595.
- [2] CISCO, Cisco Visual Networking Index: Global Mobile Data Traffic Forecast Update, 2016–2021 White Paper. URL <https://www.cisco.com/c/en/us/solutions/collateral/service-provider/visual-networking-index-vni/mobile-white-paper-c11-520862.html>.
- [3] FETTWEIS, G. and ALAMOUTI, S. (2014) 5G: Personal mobile internet beyond what cellular did to telephony. *IEEE Communications Magazine* 52(2): 140–145. doi:10.1109/MCOM.2014.6736754.
- [4] IJAZ, A., ZHANG, L., GRAU, M., MOHAMED, A., VURAL, S., QUDDUS, A.U., IMRAN, M.A. *et al.* (2016) Enabling massive IoT in 5g and beyond systems: Phy radio frame design considerations. *IEEE Access* 4: 3322–3339.
- [5] WANG, P., XIAO, J. and P, L. (2006) Comparison of orthogonal and non-orthogonal approaches to future wireless cellular systems. *IEEE Vehicular Technology Magazine* 1(3): 4–11. doi:10.1109/MVT.2006.307294.
- [6] SAITO, Y., KISHIYAMA, Y., BENJEBBOUR, A., NAKAMURA, T., LI, A. and HIGUCHI, K. (2013) Non-orthogonal multiple access (noma) for cellular future radio access. In *Proc. IEEE 77th Vehicular Technology Conf. (VTC Spring)*: 1–5. doi:10.1109/VTCSpring.2013.6692652.
- [7] ISLAM, S.M.R., AVAZOV, N., DOBRE, O.A. and KWAK, K. (2017) Power-domain non-orthogonal multiple access (noma) in 5g systems: Potentials and challenges. *IEEE Communications Surveys Tutorials* 19(2): 721–742. doi:10.1109/COMST.2016.2621116.
- [8] DAI, L., WANG, B., YUAN, Y., HAN, S., I, C. and WANG, Z. (2015) Non-orthogonal multiple access for 5g: solutions, challenges, opportunities, and future research trends. *IEEE Communications Magazine* 53(9): 74–81. doi:10.1109/MCOM.2015.7263349.
- [9] HOSHYAR, R., WATHAN, F.P. and TAFAZOLLI, R. (2008) Novel low-density signature for synchronous CDMA systems over AWGN channel. *IEEE Transactions on Signal Processing* 56(4): 1616–1626. doi:10.1109/TSP.2007.909320.
- [10] AL-IMARI, M., XIAO, P., IMRAN, M.A. and TAFAZOLLI, R. (2014) Uplink non-orthogonal multiple access for 5g wireless networks. In *Proc. 11th Int. Symp.*

- Wireless Communications Systems (ISWCS)*: 781–785. doi:10.1109/ISWCS.2014.6933459.
- [11] NIKOPOUR, H., YI, E., BAYESTEH, A., AU, K., HAWRYLUK, M., BALIGH, H. and MA, J. (2014) Scma for downlink multiple access of 5g wireless networks. In *Proc. IEEE Global Communications Conf*: 3940–3945. doi:10.1109/GLOCOM.2014.7037423.
- [12] HIGUCHI, K. and BENJEBBOUR, A. (2015) Non-orthogonal multiple access (noma) with successive interference cancellation for future radio access. *IEICE Transactions* **98-B**: 403–414.
- [13] VANKA, S., SRINIVASA, S., GONG, Z., VIZI, P., STAMATIOU, K. and HAENGGI, M. (2012) Superposition coding strategies: Design and experimental evaluation. *IEEE Transactions on Wireless Communications* **11**(7): 2628–2639. doi:10.1109/TWC.2012.051512.111622.
- [14] DAI, X., ZHANG, Z., BAI, B., CHEN, S. and SUN, S. (2018) Pattern division multiple access: A new multiple access technology for 5g. *IEEE Wireless Commun.* **25**(2): 54–60. doi:10.1109/MWC.2018.1700084.
- [15] ZHANG, J., CHEN, S., MU, X. and HANZO, L. (2014) Evolutionary-algorithm-assisted joint channel estimation and turbo multiuser detection/decoding for OFDM/sdma. *IEEE Transactions on Vehicular Technology* **63**(3): 1204–1222. doi:10.1109/TVT.2013.2283069.
- [16] DING, Z., SCHÖBER, R. and POOR, H.V. (2016) A general MIMO framework for noma downlink and uplink transmission based on signal alignment. *IEEE Transactions on Wireless Communications* **15**(6): 4438–4454. doi:10.1109/TWC.2016.2542066.
- [17] LIU, F. and PETROVA, M. (2018) Dynamic power allocation for downlink multi-carrier noma systems. *IEEE Communications Letters* **22**(9): 1930–1933. doi:10.1109/LCOMM.2018.2852655.
- [18] ZHANG, Y., WANG, H., ZHENG, T. and YANG, Q. (2017) Energy-efficient transmission design in non-orthogonal multiple access. *IEEE Transactions on Vehicular Technology* **66**(3): 2852–2857. doi:10.1109/TVT.2016.2578949.
- [19] YANG, J. and HUANG, W. (2016) Joint beamforming and power allocation design in non-orthogonal multiple access systems. In *Proc. Int. Computer Symp. (ICS)*: 706–709. doi:10.1109/ICS.2016.0145.
- [20] ZHU, J., WANG, J., HUANG, Y., HE, S., YOU, X. and YANG, L. (2017) On optimal power allocation for downlink non-orthogonal multiple access systems. *IEEE Journal on Selected Areas in Communications* **35**(12): 2744–2757. doi:10.1109/JSAC.2017.2725618.
- [21] WANG, K., CUI, J., DING, Z. and FAN, P. (2019) Stackelberg game for user clustering and power allocation in millimeter wave-noma systems. *IEEE Transactions on Wireless Communications* **18**(5): 2842–2857. doi:10.1109/TWC.2019.2908642.
- [22] DO, N.T., DA COSTA, D.B., DUONG, T.Q. and AN, B. (2017) A BNBF user selection scheme for noma-based cooperative relaying systems with SWIPT. *IEEE Communications Letters* **21**(3): 664–667. doi:10.1109/LCOMM.2016.2631606.
- [23] DO, T.N., DA COSTA, D.B., DUONG, T.Q. and AN, B. (2018) Improving the performance of cell-edge users in MISO-noma systems using tas and swipt-based cooperative transmissions. *IEEE Transactions on Green Communications and Networking* **2**(1): 49–62. doi:10.1109/TGCN.2017.2777510.
- [24] NASIR, A.A., TUAN, H.D., DUONG, T.Q. and DEBBAH, M. (2019) Noma throughput and energy efficiency in energy harvesting enabled networks. *IEEE Transactions on Communications*.
- [25] NGUYEN, V., TUAN, H.D., DUONG, T.Q., POOR, H.V. and SHIN, O. (2017) Precoder design for signal superposition in MIMO-noma multicell networks. *IEEE Journal on Selected Areas in Communications* **35**(12): 2681–2695. doi:10.1109/JSAC.2017.2726007.
- [26] NASIR, A.A., TUAN, H.D., DUONG, T.Q. and POOR, H.V. (2019) UAV-enabled communication using noma. *IEEE Transactions on Communications* : 1doi:10.1109/TCOMM.2019.2906622.
- [27] DING, Z., FAN, P. and POOR, H.V. (2016) Impact of user pairing on 5g nonorthogonal multiple-access downlink transmissions. *IEEE Transactions on Vehicular Technology* **65**(8): 6010–6023. doi:10.1109/TVT.2015.2480766.
- [28] MASARACCHIA, A., DA COSTA, D.B., DUONG, T.Q., NGUYEN, M. and NGUYEN, M.T. (2019) A PSO-based approach for user-pairing schemes in noma systems: Theory and applications. *IEEE Access* : 1doi:10.1109/ACCESS.2019.2926641.
- [29] LIANG, W., DING, Z., LI, Y. and SONG, L. (2017) User pairing for downlink non-orthogonal multiple access networks using matching algorithm. *IEEE Transactions on Communications* **65**(12): 5319–5332. doi:10.1109/TCOMM.2017.2744640.
- [30] LIU, F., MÄDHÄJNEN, P. and PETROVA, M. (2015) Proportional fairness-based user pairing and power allocation for non-orthogonal multiple access. In *Proc. and Mobile Radio Communications (PIMRC) 2015 IEEE 26th Annual Int. Symp. Personal, Indoor: 1127–1131*. doi:10.1109/PIMRC.2015.7343467.
- [31] ZHANG, H., ZHANG, D., MENG, W. and LI, C. (2016) User pairing algorithm with SIC in non-orthogonal multiple access system. In *Proc. IEEE Int. Conf. Communications (ICC)*: 1–6. doi:10.1109/ICC.2016.7511620.
- [32] GUO, J., WANG, X., YANG, J., ZHENG, J. and ZHAO, B. (2016) User pairing and power allocation for downlink non-orthogonal multiple access. In *Proc. IEEE Globecom Workshops (GC Wkshps)*: 1–6. doi:10.1109/GLOCOMW.2016.7849074.
- [33] CHINNADURAI, S., SELVAPRABHU, P. and LEE, M.H. (2017) A novel joint user pairing and dynamic power allocation scheme in MIMO-noma system. In *Proc. Int. Conf. Information and Communication Technology Convergence (ICTC)*: 951–953. doi:10.1109/ICTC.2017.8190822.
- [34] ZHU, L., ZHANG, J., XIAO, Z., CAO, X. and WU, D.O. (2018) Optimal user pairing for downlink non-orthogonal multiple access (noma). *IEEE Wireless Communications Letters* : 1doi:10.1109/LWC.2018.2853741.
- [35] HE, J., TANG, Z. and CHE, Z. (2016) Fast and efficient user pairing and power allocation algorithm for non-orthogonal multiple access in cellular networks. *Electronics Letters* **52**(25): 2065–2067. doi:10.1049/el.2016.3670.
- [36] SHAHAB, M.B., KADER, M.F. and SHIN, S.Y. (2016) A virtual user pairing scheme to optimally utilize the spectrum of unpaired users in non-orthogonal multiple

- access. *IEEE Signal Processing Letters* 23(12): 1766–1770. doi:[10.1109/LSP.2016.2619371](https://doi.org/10.1109/LSP.2016.2619371).
- [37] WAN, D., WEN, M., LIU, Y., JI, F., YU, H. and CHEN, F. (2017) User pairing strategy: A novel scheme for non-orthogonal multiple access systems. In *Proc. IEEE Globecom Workshops (GC Wkshps)*: 1–6. doi:[10.1109/GLOCOMW.2017.8269086](https://doi.org/10.1109/GLOCOMW.2017.8269086).
- [38] SHAHAB, M.B. and SHIN, S.Y. (2017) A time sharing based approach to accommodate similar gain users in noma for 5g networks. In *Proc. IEEE 42nd Conf. Local Computer Networks Workshops (LCN Workshops)*: 142–147. doi:[10.1109/LCN.Workshops.2017.76](https://doi.org/10.1109/LCN.Workshops.2017.76).
- [39] SHI, L., LI, B. and CHEN, H. (2017) Pairing and power allocation for downlink nonorthogonal multiple access systems. *IEEE Transactions on Vehicular Technology* 66(11): 10084–10091. doi:[10.1109/TVT.2017.2748145](https://doi.org/10.1109/TVT.2017.2748145).
- [40] ZHANG, X., WANG, J., WANG, J. and SONG, J. (2018) A novel user pairing in downlink non-orthogonal multiple access. In *Proc. IEEE Int. Symp. Broadband Multimedia Systems and Broadcasting (BMSB)*: 1–5. doi:[10.1109/BMSB.2018.8436709](https://doi.org/10.1109/BMSB.2018.8436709).