

Impact of Beacon Order and Superframe Order on IEEE 802.15.4 for Nodes Association in WBAN

Adil Sheraz¹, Wajid Ullah Khan¹, Javed Iqbal Bangash¹, Syed Irfan Ullah¹, Abdus Salam¹, Abdul Waheed Khan², Sheeraz Ahmed³

¹Department of Computing, Abasyn University Peshawar, Pakistan

²Faculty of Computing & Information Technology, Rabigh Campus, King Abdul Aziz University, Saudi Arabia

³Iqra National University, Peshawar, Pakistan

adil_2engr@hotmail.com, {arbabwajid.ullah, dr.javed.iqbal, syed.irfanullah, dr.salam}@abasyn.edu.pk, awk_career@yahoo.co.uk, sheerazahmed306@gmail.com

Abstract

IEEE 802.15.4, Low data Rate low power Wireless Personal Area Network (LR-WPAN) standard uses fixed duty cycle of the superframe operation. Fixed duty cycle operation of the stated standard suffers from several network issues like Personal Area Network (PAN) tedious initialization interval, nodes association duration, number of associated nodes, average network delay, throughput and nodes energy etc. Low duty cycle control operation with lower energy consumption of the network is one of the attractive feature of IEEE 802.15.4. Two superframe parameters Beacon Order (BO) and Superframe Order (SO) decide the beacon interval and duty cycle of the standard and has a strong impact on the performance of other network parameters. In this paper we analyze the IEEE 802.15.4 MAC with brief simulations by varying the two superframe parameters BO and SO to accomplish the finest performance of the WBAN network.

Keywords: IEEE 802.15.4, Wireless Body Area Network, Superframe, Nodes Association.

Received on 10 November 2017, accepted on 13 January 2018, published on 09 April 2018

Copyright © 2018 Adil Sheraz *et al.*, licensed to EAI. This is an open access article distributed under the terms of the Creative Commons Attribution licence (<http://creativecommons.org/licenses/by/3.0/>), which permits unlimited use, distribution and reproduction in any medium so long as the original work is properly cited.

doi: 10.4108/_____

1. Introduction

Real time monitoring in numerous applications like industry, agriculture, academia, entertainment and health care became possible due to sensor networks. Patient's having chronic diseases can be monitored regularly using wireless Body Area Networks (WBAN) [1-3]. IEEE 802.15.4 found space in Wireless Sensor Networks (WSNs), which was later on improved to use in WBAN applications and it works perfectly WBAN [4]. The sensor nodes accurately monitor the patient and pass this information to Coordinator node (CN) for further processing which can be stored in the central database and the doctors can monitor the patient's health remotely [5]. The IEEE 802.15.4 is designed for short range with low rate and low power communications [6]. The standard can work with star, peer to peer and cluster tree topologies. Beacon enable and non-beacon enable modes can be adopted for IEEE 802.15.4 with channel access

mechanisms whether it is contention or non-contention based. The simulation results show that beacon enabled mode performs better than non-beacon enabled in terms of throughput, packet drop, energy consumption and energy efficiency [7]. The non-beacon enable mode works better for average delay [6]. Fully Function Devices (FFDs) and Reduced Function Devices (RFDs) are used in WBAN [6]. FFDs has more capabilities than RFDs in computation, processing and in energy resources. FFD work as a Body Area Network (BAN) coordinator node or personal coordinator, whereas RFDs operate as sensor nodes. These sensor nodes gather physiological data such as ECG, EEG, blood pressure etc. [14]. A personal coordinator and several nodes builds a common network. BAN coordinator, the main controller of the network serves as an initiation, termination or a forwarding node. A typical WBAN network is shown in Figure 1

$$aBaseSuperFrameDuration = aBaseSlotDuration * aNumSuperFrameSlots \quad (3)$$

$$aBaseSuperFrameDuration = 60 * 16 \text{ (symbols)}$$

$$aBaseSuperFrameDuration = 960 \text{ symbols}$$

The duty cycle is derived from [12] equation as:

$$Duty Cycle (DC)\% = \frac{Superframe Duration(SD)}{Beacon Interval(BI) \times 100} \quad (4)$$

Consider BO=14 and SO=2, the DC can be calculated by using equations. (1), (2), (3) and (4):

$$BI = 2^{BO} \times aBaseSuperFrameDuration$$

$$BI = 2^{14} \times 960 = 15,728,640$$

And,

$$SD = 2^{SO} \times aBaseSuperFrameDuration$$

$$SD = 2^2 \times 960 = 3840$$

Now,

$$DC (\%) = \frac{SD}{BI} \times 100$$

$$DC (\%) = \frac{3840}{15,728,640} \times 100$$

$$DC = 0.024 \%$$

Table 1. Duty Cycle with variable BO and SO.

Parameters	Val1	Val2	Val3	Val4	Val5	Val6	Val7	Val8
BO	14	14	14	14	14	14	14	14

SO	0	2	4	6	8	10	12	14
DC (%)	0.006	0.024	0.097	0.39	1.56	6.25	25	100

The large duty cycle with longer active part (SD) gives maximum bandwidth resources, hence throughput is increased. At the same time all nodes are to be awaked for longer times, such that more energy is consumed [8]. On the other hand if the DC is small enough consumes lower power, but increases transmission latency, such that throughput is reduced. So we could say that there is a trade-off between network throughput and energy consumption of device nodes. A dynamic adjustment of BO and SO MAC for energy efficiency is presented in [13], where BO is kept constant and SO varies to achieve efficient network performance.

2.3 Nodes Association in Beacon-Enable Mode

IEEE 802.15.4 defines nodes association process in which all nodes in the network first detect the coordinator by passive scan, by using association messages they join the PAN [10]. Two types of scanning are used in the beacon-enabled mode of the standard, passive scan and orphan scan. Passive scan is used initially by nodes to discover the coordinator, after joining the network if nodes moves away from the coordinator's radio range they loses synchronization with their parent coordinator. Orphan scan is then used to relocate their parent coordinator, if failed to spot their parent coordinator a new passive scan is then performed to discover a new coordinator. The

scanning processes of the IEEE 802.15.4 is shown in figure 3 redrawn from [10].

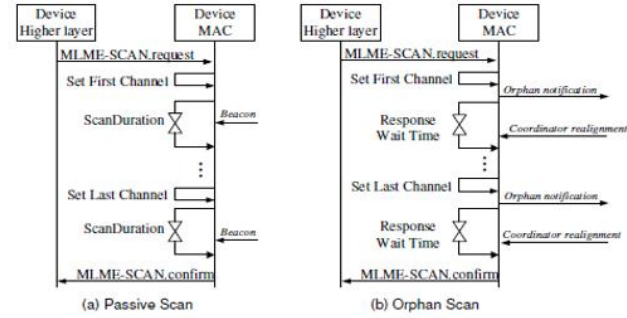

Figure 3: IEEE 802.15.4 channel scanning procedure [10]

In Figure 3, Passive scan is shown, which is used by nodes at turning it power on, or by losing connectivity with their parent coordinator. Orphan scan as shown in Figure 3 is used for relocating the parent coordinator. Association messaging process gets start upon discovering the coordinator, by sending the association request. Nodes successfully gets association with the coordinator, if association request is permitted. The Process of association messaging exchange from the nodes to coordinator is shown in figure 4 redrawn from [10].

This work focuses on analysing the performance of IEEE 802.15.4 for nodes association under frequent nodes movement scenario, when patient is moving fast without invoking of coordinator node.

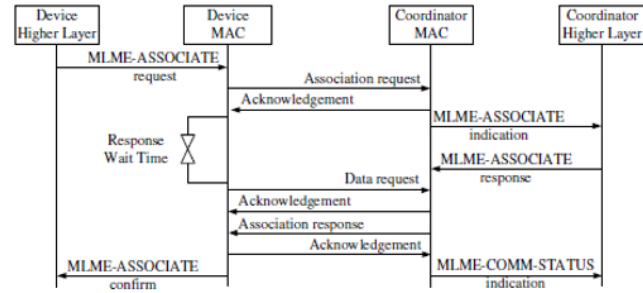

Figure 4: Nodes Association Process of IEEE 802.15.4 [10]

3 Network Model

A mobility scenario of sensor nodes for WBAN is shown in figure 5 where all sensor nodes are moving as human body is in motion; the simulation scenario is shown in Figure 6 where one BAN coordinator is deployed in the centre of the 50x50 field environment of NS2. All device nodes are mobile except BAN coordinator which is static. Setdest functionality of NS2 is used for mobility pattern generation of device nodes. The network parameters are given in Table 2.

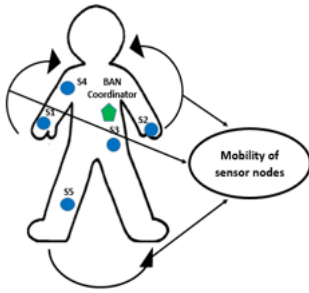

Figure 5: Mobility Scenario

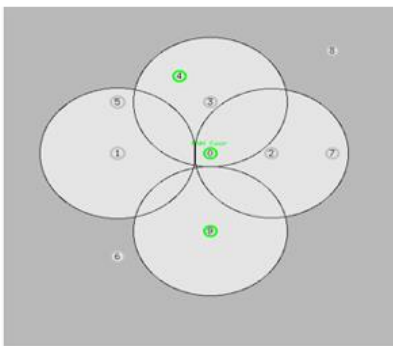

Figure 6: Network Topology in NS2

Table 2. Network Parameters

Parameters	Value
Transmission Power	56.5 mW
Reception Power	48 mW
Sleep power	30 μW
Idle power	2.79 mW
Initial Energy	10
Routing	AODV
Traffic	CBR
Packet size	100
Radio range	15 m
Frequency band	2.4 GHz

4 Simulation Results and Discussion

The scenario presented in Section 3 is simulated in NS2, by varying the Beacon Order (BO) and Superframe Order (SO) to analyse the network performance. Maximum value of BO and SO is set to 8 and decremented to 6, 4, 3, and 2 respectively. The results of all the cases are plotted in 3D graphs with the help of ORIGIN-PRO software. The detailed discussion of all graphs are given in the following subsections:

4.1 Impact of BO and SO on PAN Initialization

Figure 7 describes that by increasing BO more time the BAN takes to initialize, whereas SO doesn't affect the BAN to initialize.

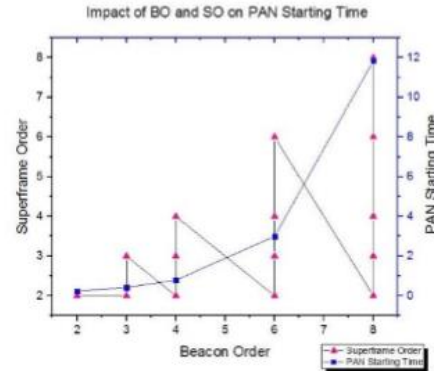

Figure 7: Initialization of BAN vs BO and SO

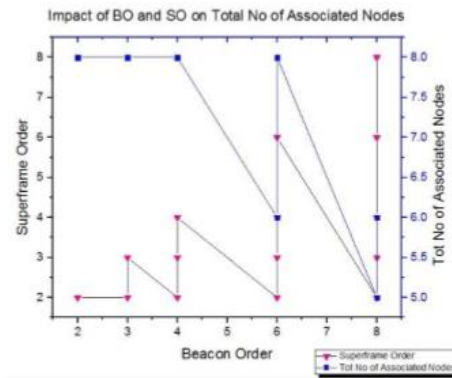

Figure 8: Total Number of Associated Nodes vs BO and SO

When the BO value is set to 2 BAN take start abruptly whereas, by setting BO to 8 it takes maximum time to initialize the PAN. Total number of associated nodes is shown in Figure 8, when the BO value is set to minimum then maximum nodes gets association with their BAN coordinator. When BO is set to 8 only 6 nodes gets association. On the other hand, the impact of SO is very less or imperceptible on both the initialization and total nodes association as shown in Figure 7 and 8.

4.2 Impact of BO and SO on Network Delay

Figure 9, 10, and 11 minimum, maximum and average delay is plotted. The graphs show that the delay is minimum near to zero when the value of BO and SO is equal. Increasing delay is lowering SO. Decreasing the SO decreasing the active part of the superframe, causing increment in delay.

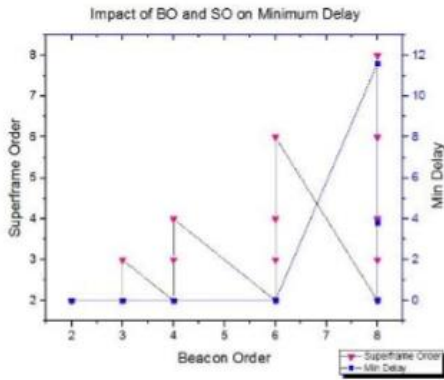

Figure 9: Minimum Delay vs BO and SO

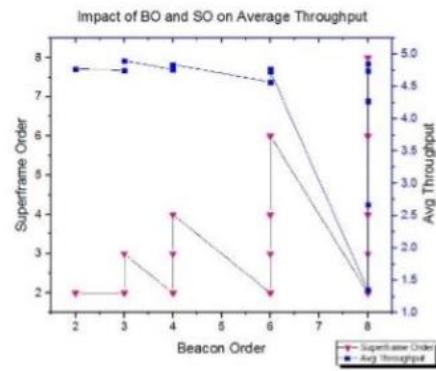

Figure 12: Average Throughput vs BO and SO

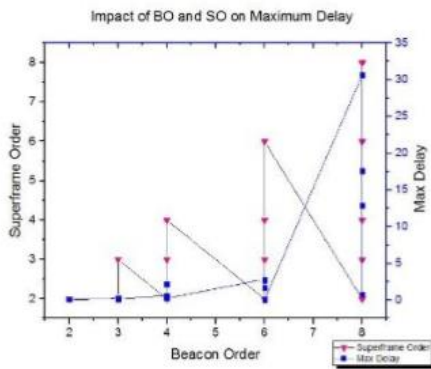

Figure 10: Maximum Delay vs BO and SO

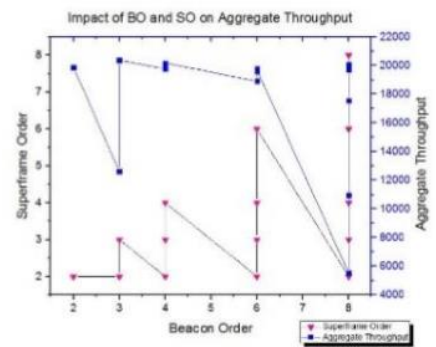

Figure 13: Aggregate Throughput vs BO and SO

Figure 13 describes the aggregate throughput results is almost same as average throughput in Figure 12. The change can be found in the network by setting the BO as 3 and SO 2 that results in decreasing the aggregate throughput to a value of 12631, the rest of the results are approximately same.

4.4 Impact of BO and SO on Average Residual Energy

The difference between initial energy and consumed energy is known as residual energy [13]. Figure 14 shows Average Residual Energy for our simulation results, by decreasing SO average residual energy of the nodes decreases. Maximum energy is consumed when the BO and SO are set equal.

4.3 Impact of BO and SO on Network Throughput

The network throughput is shown in Figure 12. Where by varying the value of BO doesn't affect the throughput of the network as at different values of BO 2, 3, 4, 6 and 8 the network throughput is almost same, except if we decrease the SO by keeping the BO constant causing to lower down the network throughput because of lower active part of the superframe.

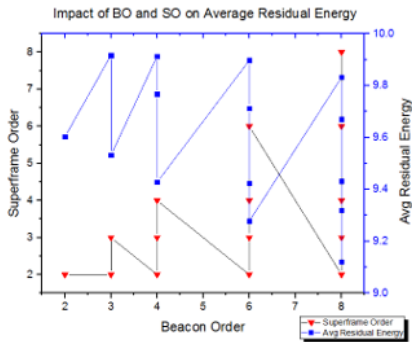

Figure 14: Average Residual Energy vs BO and SO

4.5 Impact of BO and SO on Packet Delivery Ratio

Number of dropped packets in the network due to changing BO and SO is shown in Figure 15. We found in our simulations that keeping the BO = SO, then no packets are dropped by in the network. Figure 15 show that every decrement in SO while keeping BO as constant, increasing the packets loss.

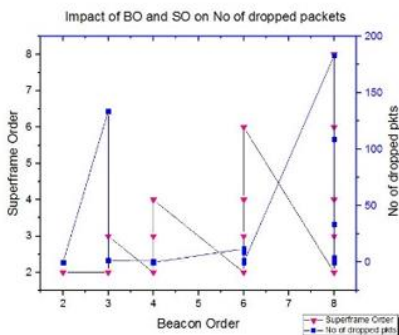

Figure 15. Number of Packets Drop vs BO and SO

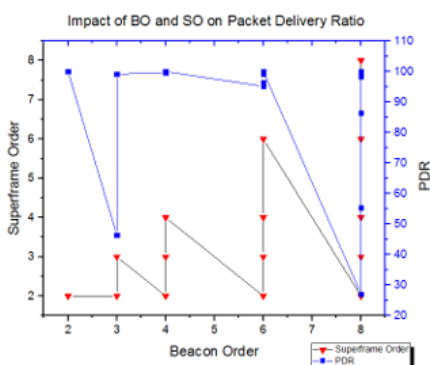

Figure 16. PDR vs BO and SO

Figure 16 represent the Packet Delivery Ratio (PDR), our simulation results show that when BO is equal to SO then PDR is 100%. And when we keep SO decreasing then PDR is going down gradually, the rate of PDR decreasing is much high at BO=8

5 Conclusion

In this work the performance of IEEE 802.15.4 has been analysed with the help of brief simulations in respect to nodes association, BAN initialization time and other network parameters. Simulation results are concisely discussed with their respective graphs. Two superframe parameters Beacon Order and Superframe Order are varied to analyse the standard for the best performance, as the standard recommends manual setting of both BO and SO. Our work contributes to the present literature in view of selecting BO and SO values for respective requirements or to design new MAC protocol especially concerning to mobility and association of nodes by keeping the impact of the simulations we present.

References

1. R. Cavallari, F. Martelli, R. Rosini, C. Buratti, and R. Verdone, "A Survey on Wireless Body Area Networks: Technologies and Design Challenges." *IEEE Communications Surveys & Tutorials*, vol. 16, no. 3, pp. 1635-1657, 2014
2. M. Chen, S. Gonzalez, A. Vasilakos, H. Cao, and V. C. M. Leung. "Body area networks: A survey." *Mobile networks and applications*, vol. 16, no. 2, pp. 171-193, 2011.
3. S. Movassaghi, M. Abolhasan, J. Lipman, D. Smith, and A. Jamalipour. "Wireless body area networks: A survey." *IEEE Communications Surveys & Tutorials*, vol. 16, no. 3, pp. 1658-1686, 2014.
4. S. Nepal, S. Dahal, and S. Shin. "Does the IEEE 802.15. 4 MAC Protocol Work Well in Wireless Body Area Networks?." *Journal of Advances in Computer Networks*, vol. 4, no. 1, 2016.
5. A. Sheraz, W. U. Khan, S. Ullah, F. Naeem, S. I. Ullah, A. Salam, A. Farhad, and H. Zafar. "A Comparative Analysis of Energy Efficient Medium Access Control Protocols for Wireless Body Area Networks." *International Journal of Computer Science and Information Security*, vol. 14, no. 9, pp. 758, 2016.
6. LAN/MAN Standards Committee. "Part 15.4: wireless medium access control (MAC) and physical layer (PHY) specifications for low-rate wireless personal area networks (LR-WPANS)." *IEEE Computer Society*, 2003.
7. M. U. H. A. Rasyid, F. A. Saputra, and M. H. R. Ismar. "Performance of multi-hop networks using beacon and non-beacon scheduling in Wireless Sensor Network (WSN)." In *Electronics Symposium (IES), 2015 International*, IEEE, pp. 195-199, 2015.
8. Y. K. Huang, A. C. Pang, and H. N. Hung. "A comprehensive analysis of low-power operation for beacon-enabled IEEE 802.15. 4 wireless networks." *IEEE Transactions on Wireless Communications*, vol. 8, no. 11, 2009.
9. A. Farhad, Y. Zia, and F. B. Hussain. "Survey of Dynamic Super-Frame Adjustment Schemes in Beacon-Enabled IEEE 802.15. 4 Networks: An Application's Perspective." *Wireless Personal Communications*, vol. 91, no. 1, pp. 119-135, 2016.
10. IEEE 802.15 Working Group. "IEEE Std. 802.15. 4-2006, Part 15.4: Wireless Medium Access Control (MAC) and Physical Layer (PHY) Specifications for Low-Rate Wireless Personal Area Networks (WPANS)", 2006.