

PhotoBeacon: Design of an Optical System for Localization and Communication in Multi-Robot Systems

Sarah Bergbreiter, Ankur Mehta, and Kristofer S. J. Pister

Berkeley Sensor and Actuator Center

497 Cory Hall

Berkeley, CA 94720, USA

{sbergbre, mehtank, pister}@eecs.berkeley.edu

Abstract – The PhotoBeacon system provides a computationally simple means for localizing and communicating among many (>50) small, autonomous mobile robots. In addition to determining the bearing of other robots for triangulation, the PhotoBeacon system can also be used to map obstacles or free space and provides a simple method for maintaining robot formations. In order to reduce the computational complexity generally required for localization, the PhotoBeacon system moves much of this complexity to silicon. The system design is broken into four basic components: a high-power LED beacon to transmit, a fisheye lens to capture transmitted light from other robots in the horizontal plane, a custom CMOS sensor chip to detect signals from other robots, and a printed circuit board (PCB) with microcontroller to control the other components. This paper presents a high-level algorithm for localization using the PhotoBeacon system as well as the design of each of the system components. In addition, some initial results are presented to demonstrate bearing measurements with the custom PhotoBeacon Sensor IC.

Index Terms – Localization, Multi-Robot Systems, Triangulation, Optical Communication

I. INTRODUCTION

Providing a means for efficient and accurate localization in unstructured environments is one of the final hurdles for large networks of small and simple robots. The robots considered as motivating examples for this work are the CotsBots – small (10 cm), inexpensive (< \$200) robots built from off-the-shelf components [1]. Each robot is equipped with on-board processing in the form of an 8-bit microcontroller, radio communication, and a base platform usually made from a toy car for mobility. To push the concept of small and simple robots even further, the robots in [1] are considered to be larger-scale examples of the microrobots described in [2].

A variety of localization schemes have been devised for robots sized similarly to the CotsBots. Odometry is a very popular and simple option where wheel turns are counted and distances calculated given the measured circumference of the wheel [3, 4]. However, error builds quickly and without a second means of localizing itself within its environment, the robot soon loses its way. Despite this, odometry may continue to offer a simple means for providing fast location updates while another more accurate, system could supply less frequent updates to reset the odometry error.

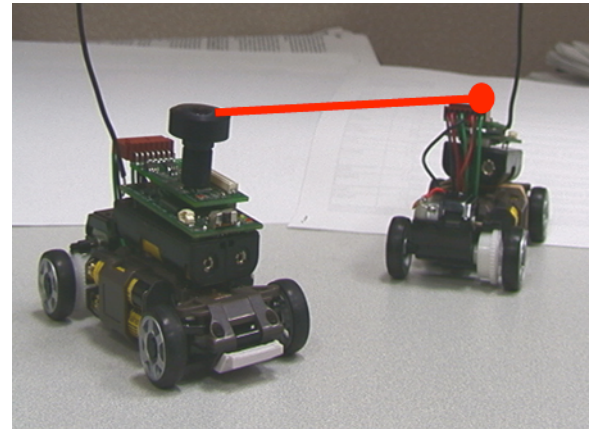

Figure 1. A conceptual view of the PhotoBeacon system for robot localization.

Another popular localization option for small robots is measuring time-of-flight (TOF). Acoustic TOF localization has previously been demonstrated with accuracies on the order of centimeters [5]. However, given a crowded, hallway-like environment, multi-path issues grow enough to significantly reduce accuracy. In addition, significant calibration may often be required for the best results. More recently, an RF TOF solution has been proposed which would use a custom ASIC to measure the distance between two robots [6]. While previous TOF methods have provided poor results in multi-path environments, this recent work demonstrated 1-3 m accuracy at very low power.

Optical methods have also gained in popularity, particularly for indoor environments. The NorthStar® system from Evolution Robotics uses optical beacons which project spots of light blinking at different rates on the ceiling [7]. Each robot uses a camera detector to determine its position and orientation within the room. The active beacon system described in [8] uses a similar system where discrete detectors located on the robot are used to obtain information from a wall-mounted rotating laser which modulates its frequency based on its current angle.

While none of these examples provides the perfect solution for localizing minimalist mobile robots in a wide variety of environments, a new idea was proposed in [9] for robots very similar to the CotsBots. In [9], each robot in the network would be equipped with an omni-directional light beacon which could transmit to other robots in the horizontal

plane. Robots also had a beacon detector which captured light from the horizontal plane within $\pm 15^\circ$. While no details on implementation were discussed, this idea is the inspiration for the localization system presented here.

The PhotoBeacon system uses the benefits of low-power optical sensing and a custom CMOS chip to provide the robot with a simple interface to determine the positions of itself and other robots in a large robot network. High power LEDs are used to communicate through a fisheye lens to the custom IC. This IC then sends information to the robot including the relative angle of other robots to its current position and heading. The system concept can be seen in Figure 1.

It should be noted that while the primary goal of the PhotoBeacon system is to provide location information, the design outlined above makes the PhotoBeacon system useful for even more purposes as outlined in [9]. The PhotoBeacon system provides a 1 kbps optical means of communication for data transmission and might also be adapted to provide line-of-sight communication for added security. In addition, due to the line-of-sight nature of an optical system, a pair of robots in optical contact will be able to determine if an obstacle has come between them. That obstacle could conceivably be mapped by pairs of robots finding vertices. Conversely, if a network of robots is spread throughout an area, they can also map the free space between them.

This paper presents an algorithm to localize the robots using triangulation as well as some of the other high-level advantages offered by this optical communication system including mapping. The design and some initial results from the PhotoBeacon system are also presented. Section II discusses a triangulation algorithm for localization. Section III outlines the requirements for the PhotoBeacon system including complexity, size, and cost along with the consequences of those design decisions. Section IV discusses the system design of the LED beacon, lens, PhotoBeacon IC sensor, and the PCB and finally Section V presents initial results from testing the PhotoBeacon IC sensor.

II. TRIANGULATION

Localization through triangulation is widely discussed in the literature although the concept is often confused with trilateration. In triangulation, the robot location is determined through measuring the angles between robots. Trilateration uses distance measurements between robots to determine position information instead.

A small sample field of robots is shown in Figure 2. A two dimensional space is filled with a collection of robots with unknown locations and orientations. One or more robots or static nodes, referred to as beacons, may have a known position and orientation. Lines of sight have been drawn in, delineating which PhotoBeacon sensors see which LEDs. For localization, the sensors return a list of which robots are in view, and at what bearing relative to an internal reference. Processing is then needed to convert this angle information into physical locations. A variety of algorithms have been proposed to solve the triangulation or multiangulation problem [10, 11].

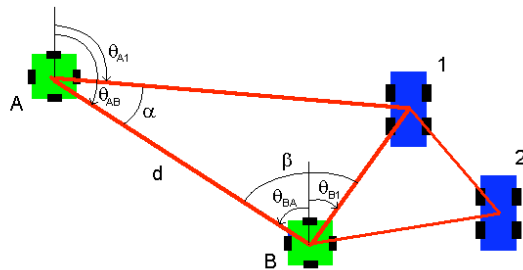

Figure 2. A small field of robots. If beacons A and B are fixed, the distance (d) between them can be calculated from their positions, as well as base angles (α , β) from PhotoBeacon measurements. The triangle AB1 is then completely defined, establishing the position of mobile robot 1. Nodes B and 1 can then similarly compute the location of mobile robot 2.

A triangle is uniquely determined (up to rotation and translation) by giving the length of a side and the measures of the internal angles at its endpoints (Figure 2). Thus, if two nodes in view of each other know their locations (i.e. they are beacons), they can identify the triangle formed with any other node in mutual view, and thus calculate its position. Once all such nodes receive their coordinates, they in turn can now repeat the process to their neighbors. In this manner, location information can be propagated through the network using local computations and line-of-sight communication with the angular data gathered by the PhotoBeacon.

While this triangulation method is computationally straightforward and does not require centralized processing, it does have its limitations. The angular measurements from the sensors are necessarily noisy and inexact; in particular, the PhotoBeacon sensor discussed in Section IV.C quantizes the angle data to a set of discrete values. This leads to uncertainty in the calculated position of node, which due to the iterative nature of the algorithm is then compounded in future calculations. In a network of large extent, the position estimation error of the fringe nodes could be large.

Multiple line of sight connectivity among a set of nodes gives additional information that can be used to reduce the localization error. To effectively use all the measurements from the PhotoBeacon sensors, a centralized omniscient processor can do a system wide optimization on the positions of all the nodes. The requirement that this master node know all the angle data does not carry significant overhead; most such multi-robot systems will have an additional system-wide communication scheme that can be used to pass such information to the master. If not, this data can also be communicated through the network via the PhotoBeacons.

The first step in calculating system-wide multiangulation localization is to normalize the orientations of the mobile nodes. Due to symmetry, pairs of nodes see each other at angles 180° apart from a common reference (Figure 3). If one is rotated relative to the other, the difference in measured angles will in turn differ from 180° by the relative rotation. Each pair of nodes with line of sight imposes a linear constraint on the unknown absolute rotations of those nodes, and these constraints can be globally solved to determine each robot orientation.

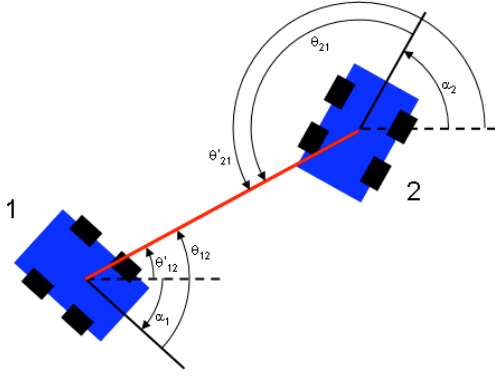

Figure 3. When measured from a common reference ("East") shown as a dotted line, mutual measured angles $\{\theta'\}$ differ by 180° . The globally referenced angles $\{\theta'\}$ equal the sum of the locally referenced angles $\{\alpha\}$ and the robot heading from the global reference $\{\alpha\}$.

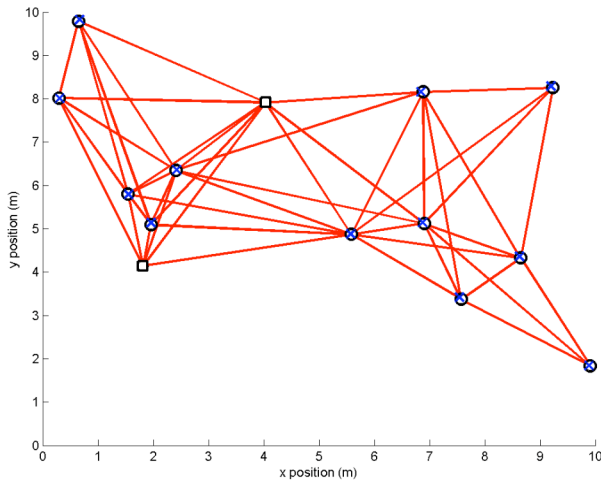

Figure 4. Lines of sight connect randomly placed robots in a simulated field. Square beacons have a known location and orientation while the positions of the circular robots are calculated using simulated PhotoBeacon sensor data. The location estimates, shown by X's, generally fall within the robots' footprints.

This orientation can then be added to the PhotoBeacon measurements to give angles between nodes from a common reference. These angles now establish the position of the nodes on specific lines in the plane relative to the other nodes. Again, each pair of nodes with line of sight imposes a linear relationship between the coordinates of the nodes. These constraints can be gathered and solved to minimize overall expected error in location.

Without any known beacons, the swarm configuration can be determined modulo global translation, rotation, and scale. A single beacon with known location and orientation fixes the translational and rotational position, while a second also determines scale. It is important to note that unlike the iterative algorithm, this method doesn't require the beacons be in mutual view of any node to localize the nodes.

The complete algorithm is summarized in Table 1. Figure 4 shows the results of this localization method on a

- 1: Gather measured angle data $\{\theta_{ij}\}$ from all nodes i that can see a node j .
- 2: For each pair of nodes (m, n) that see each other, generate an equation for their headings $\{\alpha_m, \alpha_n\}$ relative to global "East":

$$\alpha_m - \alpha_n = 180^\circ - \theta_{mn} + \theta_{nm} \pmod{360^\circ}.$$
- 3: Using the known headings of the beacons, solve the system of equations from step 2 for the unknown headings $\{\alpha\}$ of the mobile nodes.
- 4: Add each robot heading to its sensed angles $\{\theta\}$ to get globally referenced internode angles $\{\theta'\}$
- 5: For each pair of nodes (m, n) that see each other, generate a pair of equations relating their coordinates and separation distance d_i based on the global angle between them:

$$x_n = x_m + d_i \cos(\theta'_{mn})$$

$$y_n = y_m + d_i \sin(\theta'_{mn}).$$
- 6: Using the known coordinates of the beacons, solve the system of equations from step 5 for the unknown coordinates $\{x, y\}$ of the mobile nodes.

Table 1. Centralized localization algorithm

simulated robot swarm. Two square beacons are distributed in a 10 m x 10 m field along with 10 cm diameter mobile robots pictured with circles. The red lines indicate lines of sight, from which angular data, quantized according to PhotoBeacon sensor IC specifications, are collected by a central processor. The estimated positions are shown by X's on the plot. The mean error between actual and calculated positions in this simulation is 3.3 cm, well inside the extent of the robot.

Both methods can fail in certain degenerate cases, for instance when a separate sub-swarm without beacons is connected to the main swarm through at most one node. These configurations can be avoided by distributing more beacons or mobile nodes around the space (also lowering system localization error). Incidentally, if such a situation does arise in an application, mobile nodes can be dispatched in the direction of the bottlenecked connection (determined using known angle data) to "find" the lost nodes.

III. PHOTOBEACON SYSTEM REQUIREMENTS

The PhotoBeacon system is meant to provide a method of realizing the above localization algorithm for large networks of small and inexpensive robots in unstructured environments [1, 3-5]. Robots using this system are assumed to be at least 10 cm in one dimension, provide at minimum the computational resources of an 8-bit microcontroller similar to the Atmel ATmega 128, an interface for communicating with that microcontroller, and the robots should ideally possess a separate means of communicating between one another, preferably RF. The network of robots is also considered to be relatively dense with the maximum spacing between a robot and its nearest neighbor at 10 m. Based on these assumptions, the PhotoBeacon system designed here must be computationally simple, small, low power, and inexpensive to produce in large quantities.

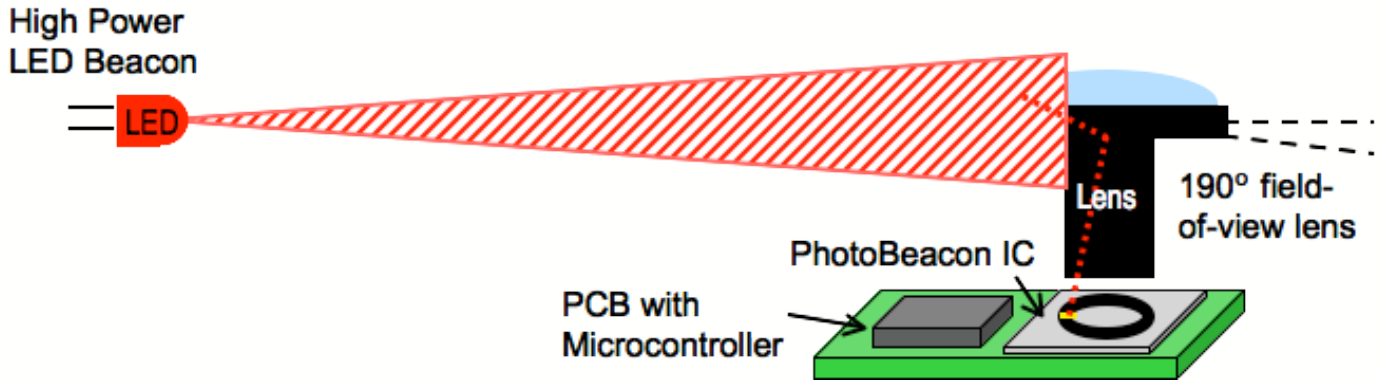

Figure 5. Design concept for PhotoBeacon system consisting of four separate components: the high power IR LEDs, a fisheye lens, the custom PhotoBeacon IC sensor, and a PCB with 8-bit microcontroller.

As mobile robots become smaller and simpler, their ability to support a complex means of localization decreases substantially. Storing large amounts of calibration data or analyzing camera images both become increasingly difficult, if not impossible, using the simple microcontrollers often found on these minimalist robots. In addition, as the numbers of robots in a network scale up, the computation required on-board the robot should not be required to scale along with this number. For the PhotoBeacon system, it is assumed that operations are limited to a few trigonometric functions as well as multiplications for which functions are already written for these microcontrollers and limited data tables are required. For simplicity, it may also be assumed that the robots stop in place while localizing themselves.

Since the robot is assumed to be small, the PhotoBeacon system should remain compact as well. The system size includes any lenses, PCBs, and connectors required. Dimensions should be on the order of 5 cm x 3 cm and mass should be kept minimal. Ideally the PhotoBeacon size should also be able to scale down with the size of the robot as new technologies become available. Small robots also tend to carry small batteries implying that the PhotoBeacon system should be low power as well.

Finally, the system should be inexpensive if produced in mass quantities. As robots grow smaller and networks of robots become larger, the manufacture of tens of thousands of localization systems is not unreasonable. Therefore, while the single quantity system demonstrated in this paper may be costly, scaling up production should result in a substantial price decrease.

IV. PHOTOBEOACON DESIGN

To satisfy the system requirements listed above, the PhotoBeacon localization system moves much of the complexity to hardware. Using custom hardware which could be mass produced allows the PhotoBeacon system to remain computationally simple, small, and inexpensive. Towards this end, the system is broken into four components: an LED omni-directional beacon, a fisheye lens, a custom CMOS sensor chip, and a printed circuit board with attached microcontroller (Figure 5).

A. LED Beacon

The LED beacon is the optical transmitter in the PhotoBeacon system. This beacon should be omni-

directional, provide appropriate power for the receiver discussed in Section C without burning too much power itself, as well as be able to transmit despite ambient lighting conditions. Lastly, it should also be low-cost when produced in large quantities and compact in size.

To keep the system simple and costs low, LEDs are chosen as transmitters. In order to transmit a signal in all directions, the LEDs should be positioned around the receiver such that their viewing angles provide appropriate coverage. If a given LED has a 110° viewing angle, 4 LEDs should be positioned around the receiver. There is a trade-off between an LED with large viewing angle which may require more current to drive it and an LED with smaller viewing angle which may require less current but more LEDs to cover the same area. This tradeoff should be considered when choosing an LED in order to keep the drive current low. While not assumed in this analysis, an additional oval-type lens may be added to a wide angle LED to minimize the vertical dispersion but keep the horizontal angle large. It is assumed that the field of view of the fisheye lens in the plane will be smaller than any viewing angle of the LEDs so elevation differences between robots is not considered here.

Driver circuits for LEDs are common and many microcontrollers also provide I/O pins capable of sinking up to 20 mA for driving LEDs directly. An optical signal can be sent by simply switching the LEDs on and off using the microcontroller. Since the receiver is designed to ignore DC lighting conditions, ambient light should not interfere with transmission.

Assuming that all of the nearby robots in the network can now see the beacon, the next question of interest in choosing an LED is the received power of the signal given the distance between beacon and receiver. One difficulty that arises when examining LED specifications is the difference between luminous intensity measured in candelas and radiant intensity measured in W/sr, where the steradian is unit of solid angle. Given an LED where brightness is specified in candela, the luminous flux may be calculated in lumens.

$$Flux_{rx} = I_{tx} 2\pi(1 - \cos(0.5\theta)) \quad (1)$$

Table 2. Received signal power and corresponding signal current at distance given LED specified above and aperture specified below.

Distance (m)	P_{rx} (pW)	i_{sig} (pA)
1	8170	3023
2.5	1307	484
5	327	121
7.5	145	54
10	82	30

I_{rx} is the radiant intensity of the transmitting LED and θ is the beam angle specified. The calculation to determine radiant power from luminous flux takes into account the response of the human eye to that wavelength. A green LED and red LED with the same luminous flux have substantially different radiant powers with the red LED approximately 10x more power than the green. For the initial PhotoBeacon system, red LEDs will be used to provide the maximum radiated power. Infrared emitting diodes (IREDS) are also a good choice here but testing becomes more complex without visual feedback. For a red LED with 640 nm wavelength, the conversion factor, η , is approximately 120 Lumens/Watt. Given a distance between the beacon and receiver (d), and an aperture area for the lens (A), the received input power (P_{rx}) for the PhotoBeacon sensor can be calculated.

$$P_{rx} = \frac{Flux_{tx} A}{\eta d^2} \quad (2)$$

With the assumption that the robots are at most 10 m away from each other, the received power from a SunLED super flux LED (XSZE383W) with a luminous intensity of 2390 mcd and 110° beam angle can be calculated given the lens aperture defined below. At 10 m, the received power through an aperture 0.44 mm in diameter will be only 82 pW. Detecting signals with such a low power will be a challenge for the sensor design in Section C. Table 2 shows the received power numbers and corresponding signal current for several different distances.

B. Fisheye Lens

In order to sense light coming from other robots in the horizontal plane, a fisheye lens is required to focus the light from the LED beacons onto the sensor. In the simplest case,



Figure 7. The OmniTech fisheye lens with 190° field of view [12].

all of the robots will be on the same plane and the lens would require only a small +/- 1° field of view around the horizontal plane. In more complex environments with elevation changes, the field of view required by the fisheye lens could increase. For example, if it assumed that the robots are no closer than 1 m apart when the elevation difference is greater than 10 cm, the fisheye lens would require +/- 6° field of view.

For the initial PhotoBeacon system, a miniature fisheye lens has been chosen from Omnitech Robotics [12]. This lens has a 190° field of view (-5° below the plane), a 2.4 cm top diameter and is 2.6 cm high. A picture is shown below in Figure 7. The important optical numbers for this lens are a focal length of 1.24 mm and an F/number of 2.8. This gives a small aperture diameter of 0.44 mm which implies that it will be difficult to get enough light from the other robots to meet the 10 m distance specification. The field diameter is 3.4 mm which means the array of photodiodes on the PhotoBeacon IC will need to have at least that diameter.

C. PhotoBeacon Sensor IC

The custom PhotoBeacon Sensor IC is perhaps the most interesting and challenging design aspect of this system. This sensor needs to be able to detect very low power incident signals and resolve the relative angle to approximately 1° to work well with the triangulation algorithm specified in Section II. In addition, the chip itself should be low power and provide a relatively simple interface to any external controllers.

The PhotoBeacon IC architecture shown in Figure 6 is repeated twice on the fabricated IC seen in Figure 8 so that each half of the die can be scanned simultaneously. The PhotoBeacon IC uses 256 photodiodes arrayed in the shape of an annulus to detect incoming signals. If light is focused onto a single pixel, the angle of incidence may be determined to approximately 1.4°. These photodiodes are multiplexed into a modified version of the 1 Mbps optical receiver described in [13]. This optical receiver includes three switchable sense resistors and a gain stage which can provide up to 33 dB of gain. In addition, it also provides a way to discard DC current from ambient light (discussed further in [13]). The receiver and multiplexor are controllable over a simple 3-wire serial interface.

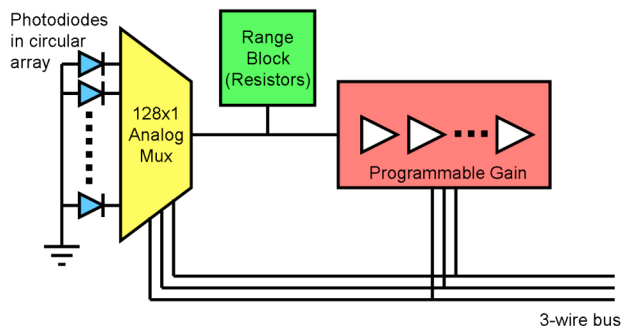

Figure 6. Architecture of one half of the PhotoBeacon IC sensor.

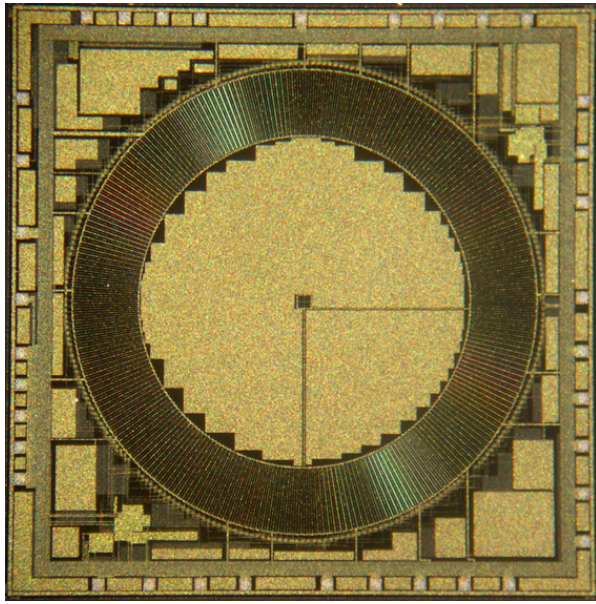

Figure 8. Die photo of PhotoBeacon IC fabricated in 0.25 μm CMOS process.

The photodiodes on the PhotoBeacon IC convert incoming optical power to a current according to the diode's responsivity. For n-well photodiodes in the 0.25 μm CMOS process used, responsivity has been measured at approximately 0.36 A/W at 660 nm wavelength. The photodiodes are connected in series with a sense resistor in the range block to provide a voltage input for the first stage of the variable gain amplifier (VGA). The gain and offset of each amplifier stage can be set independently through switches controlled by the 3-wire serial bus. A differential output is then provided off-chip.

The optical receiver, and specifically the range block and VGA, have been modified from the receiver in [13] to lower the minimum detectable signal by trading off system bandwidth. To accomplish this, the three sense resistors were multiplied by a factor of 300 to get 30 M Ω , 3 M Ω and 300k Ω . The input referred noise current at the first stage of the VGA is described by the equation below, where k is Boltzmann's constant, T is the absolute temperature, R is the value of the sense resistor, and Δf is the signal bandwidth.

$$i_n^{-2} \cong 2 \left(\frac{4kT}{R} \right) \frac{\pi}{2} \Delta f \quad (3)$$

The factor of two in front represents the fact that the resistor noise should be approximately the same order of magnitude as the amplifier noise. Given a desired signal to noise ratio (SNR) of at least 10:1 and the responsivity of 0.36 A/W, the

Table 3. Received signal currents and power for different bit rates.

Bandwidth (Hz)	i_n (pA)	i_{sig} (pA)	P_{rec} (pW)
100	0.14	1.4	3.7
200	0.19	1.9	5.2
1000	0.43	4.3	11.7
2000	0.61	6.1	16.5
10000	1.37	13.7	36.9

minimum received power may be calculated and is shown in Table 3.

According to Table 3 the receiver requires a minimum of 17 pW received power in order to use a 2000 Hz bandwidth which corresponds to a 1 kbps bit rate. To confirm the receiver can meet these specifications and provide a voltage at the output reasonable for a 10-bit ADC to capture, the receiver was simulated with a 30 pA input current at 2 kHz. The results are seen in Figure 9. The 160 mV voltage swing utilized the 30 M Ω sense resistor and maximum gain and can easily be read by a 10-bit ADC. Referring back to Table 2, 30 pA corresponds to the received signal current from the LED beacon at 10 m.

As stated previously, the primary purpose of creating a custom IC was to simplify the interface to the robot and minimize the computation required. The PhotoBeacon IC multiplexor, gain, and offset bits are controlled over a simple 3-wire serial bus. Using the current multiplexor position and analog output, a microcontroller with a 10-bit ADC can determine if another robot is signaling at some bearing with respect to its own frame and detect the message encoded in that signal. This small amount of data is compact enough for the robot to forward on in a centralized localization scheme and simple enough for the robot to manipulate itself in distributed triangulation.

D. PhotoBeacon System PCB

While more digital circuitry could be added to future versions of the PhotoBeacon Sensor IC to provide an interface directly to the host robot, a microcontroller is currently required to interpret the data from and control the sensor chip. In addition, external components required by the sensor chip as well as the driver circuits for the LEDs will be included on the PhotoBeacon system PCB. The PhotoBeacon IC provides an analog output which needs to be converted to a digital number before it can be analyzed. For this reason, the primary requirement for the included microcontroller is an ADC with at least two differential channels. The microcontroller should also provide outputs for controlling the LED beacon as well as a serial bus to use with the 3-wire bus on the PhotoBeacon IC. Any

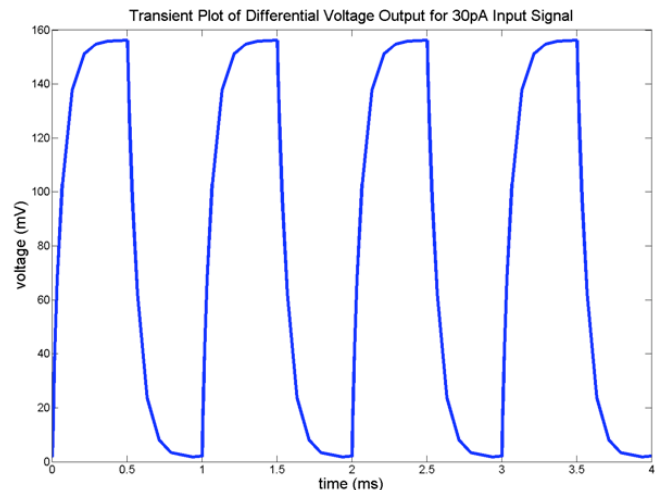

Figure 9. Transient simulation of 30 pA signal current at 2 kHz.

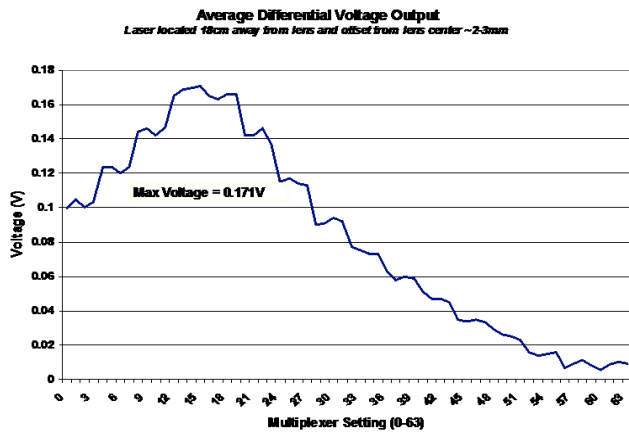

Figure 10. PhotoBeacon IC voltage output for each of 64 photodiodes on a separately fabricated quarter ring die.

microcontroller similar to the Atmel ATmega128 or TI MSP430 should suffice.

V. RESULTS

The full PhotoBeacon localization system is currently being built and tested. Initial results have been gathered from the fabricated PhotoBeacon IC using a test setup in which LabView provides the user interface to control the 3-wire bus and a 660 nm 5 mW laser pointer was currently being used in place of the LED beacon. The fisheye lens was positioned over the IC using a 3-axis manipulator.

A smaller die with only a quarter ring of 64 diodes was tested first. Due to limitations of the current IC packaging, it was not possible to achieve the appropriate focal length so light was diffused across the die. In order to demonstrate basic functionality however, the multiplexor was sequenced over the diode array and the analog output is plotted in Figure 10. A definite peak exists at diode 16 which was oriented towards the laser indicating that bearing measurements can still be gathered if only one beacon transmits at a time. Future tests will use more appropriate packaging to achieve the desired focal length as well as the same LED beacon that will be used on the robots.

VI. CONCLUSIONS AND FUTURE WORK

This paper has outlined the design of the PhotoBeacon localization system for large networks of small, low-cost robots. The PhotoBeacon system is simple to interface with, compact, low power, and provides a means to both localize and communicate within a network of robots where the robots can be up to 10 m from each other. The custom PhotoBeacon IC was designed, fabricated, and initial testing results look promising.

The next step will be to finish testing the PhotoBeacon IC and fully implement the entire system including the LED beacon, fisheye lens, PhotoBeacon IC, and PCB with

microcontroller. Once the full system has been built and tested, the triangulation algorithm may then be tested on real hardware to localize simple minimalist mobile robots.

ACKNOWLEDGMENTS

We would especially like to thank Brian Leibowitz who provided instruction and guidance while designing and laying out the PhotoBeacon IC. He also provided the original optical receiver schematic and layout which was modified in this paper.

REFERENCES

- [1] S. Bergbreiter and K. S. J. Pister, "CotsBots: An Off-the-Shelf Platform for Distributed Robotics," in *IEEE International Conference on Intelligent Robots and Systems*, Las Vegas, NV, 2003, pp. 1632-1637.
- [2] S. Hollar, A. Flynn, C. Bellew, and K. S. J. Pister, "Solar powered 10 mg silicon robot," in *IEEE Sixteenth Annual International Conference on Micro Electro Mechanical Systems*, Kyoto, Japan, 2003, pp. 706-11.
- [3] M. B. McMickell, B. Goodwine, and L. A. Montestrucque, "MICAbot: a robotic platform for large-scale distributed robotics," in *2003 IEEE International Conference on Robotics and Automation*, Taipei, Taiwan, 2003, pp. 1600-5.
- [4] G. T. Sibley, M. H. Rahimi, and G. S. Sukhatme, "Robomote: a tiny mobile robot platform for large-scale ad-hoc sensor networks," in *2002 IEEE International Conference on Robotics and Automation*, Washington D.C., 2002, pp. 1143-8.
- [5] L. E. Navarro-Serment, R. Grabowski, C. J. J. Paredis, and P. K. Khosla, "Millibots: The development of a framework and algorithms for a distributed heterogeneous robot team," *IEEE Robotics & Automation Magazine*, vol. 9, pp. 31-40, 2002.
- [6] S. Lanzisera, D. Lin, and K. Pister, "RF Time of Flight Ranging for Wireless Sensor Network Localization," in *4th Workshop on Intelligent Solutions in Embedded Systems*, Vienna, Austria, 2006.
- [7] Y. Yamamoto, P. Pirjanian, M. Munich, E. DiBernardo, L. Goncalves, J. Ostrowski, and N. Karlsson, "Optical sensing for robot perception and localization," in *IEEE Workshop on Advanced Robotics and its Social Impacts*, Nagoya, Japan, 2005, pp. 14-17.
- [8] T. Venet, T. Capitaine, M. Hamzaoui, and F. Fazzino, "One active beacon for an indoor absolute localization of a mobile vehicle," in *IEEE International Conference on Robotics and Automation (ICRA2002)*, Washington, DC, 2002, pp. 1-6.
- [9] D. Gage, "Minimum-resource distributed navigation and mapping," in *SPIE Mobile Robots XV*, Boston, MA, 2000.
- [10] J. S. Esteves, A. Carvalho, and C. Couto, "Generalized geometric triangulation algorithm for mobile robot absolute self-localization," in *IEEE International Symposium on Industrial Electronics*, Rio de Janeiro, Brazil, 2003, pp. 346 - 351.
- [11] J. N. Ash and L. C. Potter, "Robust System Multiangulation Using Subspace Methods," in *International Conference on Information Processing in Sensor Networks* Cambridge, MA, 2007.
- [12] Omnitech Robotics, "Omnitech Robotics - Fisheye Lens for 1/3-inch Image Sensor Video Cameras," <http://www.omnitech.com/fisheye.htm>, 2004.
- [13] B. S. Leibowitz, B. E. Boser, and K. S. J. Pister, "A 256-element CMOS imaging receiver for free-space optical communication," *IEEE Journal of Solid-State Circuits*, vol. 40, pp. 1948-1956, September 2005.