

Channel Estimation and Equalization for Fixed/Mobile OFDM WiMAX System in Simulink

Onsy Abdel Alim
Prof., Faculty of
Engineering, Elect. Eng.
Dept., Alexandria
University, Egypt

Nemat Elboghhdady
Dr., Faculty of
Engineering Elect. Eng.
Dept., Alexandria
University, Egypt

Mahmoud Ashour
Prof., National Center
for Radiation Research
and Technology
(NCRRT), Egypt

Azza M. Elaskary
Eng., National Center for
Radiation Research and
Technology (NCRRT)
Egypt
azza48@hotmail.com

ABSTRACT

WiMAX (Worldwide Interoperability for Microwave Access) is a technology for wireless broadband and the core technique for the fourth-generation (4G) wireless mobile communications. However it still facing real challenge for low complexity and efficient system implementation. It supports non-line-of-sight environment with high data rate transmission and high mobility up to 125 Km/hr. WiMAX adopted OFDM/OFDMA in physical layer for fixed/mobile applications respectively. Integrated WiMAX model including Channel estimation and equalization are an active area for many recent researches. This paper presents a model for simulating OFDM WiMAX system in Simulink including channel estimation and equalization subsystems in MATLAB functions. Performance has been tested applying Additive White Gaussian Noise (AWGN) channel for fixed system and Doppler shifts due to changes in high and low relative velocity has been calculated and applied to the Simulink channel model for mobile system. Different iterative approaches for channel estimation and equalization have been modeled and evaluated. BER versus SNR curves at high and low Doppler shifts have been used for comparing these models.

Keywords

WiMAX, OFDM, Channel Estimation, Equalization, Doppler Effect

1. INTRODUCTION

WiMAX is a new broadband wireless access technology that provides very high data throughput over long distance in a point-to-multipoint and line of sight (LOS) or non-line-of-sight (NLOS) environments. In terms of the coverage, WiMAX can provide services up to 20 or 30 miles away from the base station. WiMAX is based on wireless metropolitan area networking (WMAN) standards developed by the IEEE 802.16 group. IEEE group completed and approved IEEE 802.16e-2005, a standard that added mobility support. The IEEE 802.16e-2005 forms the basis for the WiMAX solution for mobile applications and is often referred to as mobile WiMAX [1]. Orthogonal Frequency Division Multiplexing (OFDM) technique is widely adopted in wireless systems due to its robustness against Multipath fading and simpler equalization scheme. In most of applications, for

retaining the orthogonality of subcarriers and overcome intersymbol interference (ISI), a cyclic prefix (CP) is inserted instead of simply inserting guard interval. If the maximum delay of the Multipath channel does not exceed the CP length, the OFDM system would be ISI free by removing the guarding interval. For WiMAX systems, its delay spread is typically over several micro-seconds which are longer than the guarding interval. Therefore, it is very challenging to maintain the system BER performance for non-line-of-sight (NLOS) channels at high data rate transmission. In mobile WiMAX, mobility directly translates to Doppler Effect dynamics, which degrades the system performance. To combat the multipath and Doppler effects, wireless communications both, the equalizer or channel estimator can be applied to compensate for the attenuation and phase shift introduced by the channel. Equalization and channel estimation basically it is simple for OFDM systems but it needs careful consideration due to their implementation limitations to accomplish the trade-off between complexity and accuracy. This paper introduces an end to end WiMAX system model including channel estimation and equalization to facilitate evaluation of performance in fixed/mobile system. This paper is organized as follows. In section 2 we will introduce the background of IEEE 802.16 standards packet format, channel estimation and equalization techniques. Then, Simulink models architecture is presented in Section 3. Results and discussion are provided in Section 4. Finally, in section 5 conclusions are summarized.

2. BACKGROUND

The WiMAX physical layer is based on orthogonal frequency division multiplexing. OFDM is the transmission scheme of choice to enable high-speed data, video, and multimedia communications. The WiMAX Forum has two different system profiles: one based on IEEE 802.16-2004, OFDM PHY, called the fixed system profile; the other one based on IEEE 802.16e-2005 scalable OFDMA PHY, called the mobility system profile [2]. In the following brief description for these standards and overview for channel estimation and equalization approaches

2.1. Fixed WiMAX OFDM-PHY

For this version the FFT size is fixed at 256, which 192 subcarriers used for carrying data, 8 used as pilot subcarriers for channel estimation and synchronization purposes, and the rest used as guard band subcarriers. Since the FFT size is fixed, the subcarrier spacing varies with channel bandwidth. When larger bandwidths are used, the subcarrier spacing increases, and the symbol time decreases. Decreasing symbol time implies that a larger fraction needs to be allocated as guard time to overcome delay spread. WiMAX allows a wide range of guard times that allow system designers to make appropriate trade-offs between spectral efficiency and delay

spread robustness. For maximum delay spread robustness, a 25 percent guard time can be used, which can accommodate delay spreads up to 16 μ s when operating in a 3.5MHz channel and up to 8 μ s when operating in a 7MHz channel as shown in table 1[3].

Table 1. Table Represent WiMAX Phy. Layer Specifications [3]

Parameter	Fixed WiMAX OFDM-PHY		Mobile WiMAX Scalable OFDMA-PHY ^a		
	256	128	512	1,024	2,048
Number of used data subcarriers ^b	192	72	360	720	1,440
Number of pilot subcarriers	8	12	60	120	240
Number of null/guardband subcarriers	56	44	92	184	368
Cyclic prefix or guard time (T _g /T _b)	1/32, 1/16, 1/8, 1/4				
Oversampling rate (F _s /B _W)	Depends on bandwidth: 7/6 for 256 OFDM, 8/7 for multiples of 1.75MHz, and 28/25 for multiples of 1.25MHz, 1.5MHz, 2MHz, or 2.75MHz.				
Channel bandwidth (MHz)	3.5	1.25	5	10	20
Subcarrier frequency spacing (kHz)	15.625		10.94		
Useful symbol time (μ s)	64		91.4		
Guard time assuming 12.5% (μ s)	8		11.4		
OFDM symbol duration (μ s)	72		102.9		
Number of OFDM symbols in 5 ms frame	69		48.0		

2.2. Mobile WiMAX OFDMA-PHY

Mobile WiMAX is intended for the 2.3 GHz, 2.5 GHz and 3.5 GHz [4] spectra. The system is defined so that the user can travel at speeds between 0-125 km/h. The theoretical upper limit for the bit rate in WiMAX, given a bandwidth of 10 MHz, is 31 Mbps in downlink and 23 Mbps in uplink [5]. The base stations have a typical coverage up to an 8 km radius in a NLOS environment. In Mobile WiMAX, the FFT size is scalable from 128 to 2,048. Here, when the available bandwidth increases, the FFT size is also increased such that the subcarrier spacing is always 10.94 kHz. The subcarrier spacing of 10.94 kHz was chosen as a good balance between satisfying the delay spread and Doppler spread requirements for operating in mixed fixed and mobile environments. This subcarrier spacing can support delay-spread values up to 200 μ s and vehicular mobility up to 125 kmph when operating in 3.5GHz. A subcarrier spacing of 10.94 kHz implies that 128, 512, 1,024, and 2,048 FFT are used when the channel bandwidth is 1.25MHz, 5MHz, 10MHz, and 20MHz, respectively. The OFDM symbol frequency domain description in WiMAX is illustrated in Figure 1.

There are three types of OFDM subcarriers:

1. Data subcarriers for data transmission.
2. Pilot subcarriers for various estimation and synchronization purposes.
3. Null subcarriers for no transmission at all, used for guard bands and DC carriers.

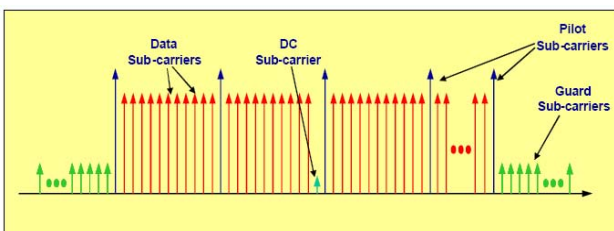

Figure 1. OFDM Sub-Carrier Structure [4]

In Fig. 1, total of 256 subcarriers are spread to four parts. There are 192 subcarriers for data transmission, 8 subcarriers

for pilot tone, 52 subcarriers for guard bands, and 1 subcarrier for DC in every OFDM symbol.

2.3. Channel Estimation & Equalization

The function of channel estimation is to form an estimate of the amplitude and phase shift caused by the wireless channel from the available pilot information. The equalization removes the effect of the wireless channel and allows subsequent symbol demodulation. A number of different algorithms can be employed for these modules.

There are two major kinds of channel estimators that are found in literature, namely pilot assisted and blind estimation. In training sequence methods or non-blind methods, the transmitted data and training sequences known to the receiver are embedded into the frame and sent through the channel. Main advantages of training sequences are the conceptual simplicity of the method, which is facilitated in some new communication standards that includes frames for sending training sequences. Obviously, the drawback is because the time-slots occupied in the transmission of these training sequences, reducing throughput.

In blind methods, mathematical or statistical properties of transmitted data are used. They are bandwidth efficient however, they are significantly slow to converge and require important computational capacity. A mixture of these two, where a blind method with limited training symbols is used, is called semi-blind technique. The semi-blind methods use information from both training sequence and statistical properties of the transmitted signal, which makes them more robust than the blind methods while they still require less training compared to the non-blind methods. Traditional one-dimensional channel estimation techniques for the OFDM systems can be summarized as follows: Least Squares (LS), Minimum Mean Squared Error (MMSE) and linear MMSE (LMMSE). LS estimators are very simple to constitute, but they suffer from MSE in low SNR conditions. MMSE, based on time domain estimations, are high complexity estimators that provide good performance in sampled-spaced channels, but limited performance in non-sample spaced channels and high SNR conditions. The third one, LMMSE provides good performance in both sampled and non-sampled channels [6].

3. MODELING WiMAX SYSTEM

MATLAB and Simulink are used for modeling the WiMAX OFDM physical layer [7]. Simulink provides a very powerful extension to MATLAB for modeling and simulation of many types of systems especially communication systems. It provides set of ready block library. It is suitable for multidomain and dynamic system simulation using graphical user interface. Modeling the physical layer was in three steps first implement the WiMAX transmitter second WiMAX receiver and at last end-to-end system with channel estimation and equalization model.

3.1. WiMAX transmitter model

The WiMAX standard provides specific instantiations of the physical layer data vectors (Input data, randomization, coding, and Interleaving) for different code rates (concatenated Reed Solomon and Convolutional Coding) and modulation schemes (M-QAM, QPSK) are published as case studies [4,8]. To ensure proper transmitter implementation, the transmitter has been modeled in accord with the standard for this specific configuration. Figure 2 shows the MATLAB Simulink model for transmitter. Figure 3 shows the OFDM Symbol creation model. The input and output data vector is read in and written to MATLAB workspace after each major function block then it is compared to the standard test

vector and it was identical. Additional functions are required for proper transmitter modeling but it was the same as in WLAN OFDM system such as Inverse Fast Fourier Transformed (IFFT) and cyclic prefix addition to the OFDM Symbol. All these additional elements have been modeled and added to ensure compatibility.

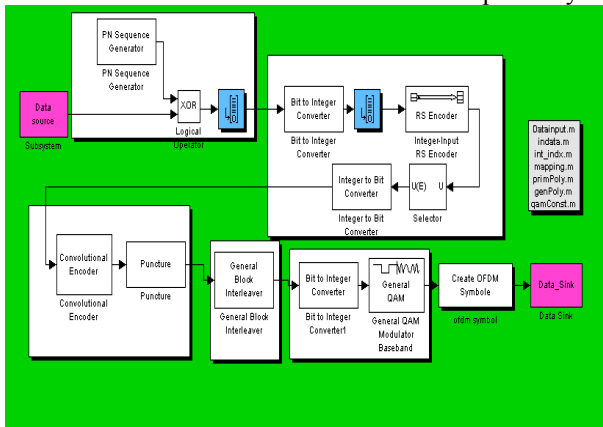

Figure 2. MATLAB Simulink WiMAX Transmitter Model

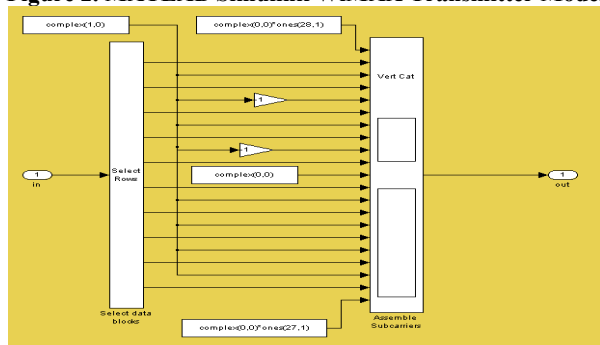

Figure 3. OFDM symbols creation

3.2. Doppler channel model

When a transmitter and a receiver are moving relative to one another the frequency of the received signal is higher than the source if they approach each others. When they are moving away from each other the received frequency decreases. This is called the Doppler Effect. The frequency change due to the Doppler Effect depends on the relative motion between the source and receiver, the angle of arrival of the incident wave, as well as the speed of propagation of the wave. The Doppler shift attains its maximum value when the incident ray is collinear with the direction of the receiver's motion. The steps that have been performed to implement the channel in our simulator started from the WiMAX specifications. A

maximum speed of 125 km/hr is used here in the analysis as a high mobility value. The Doppler frequency $f_{doppler}$ can be approximately computed as [9]

$$f_{doppler} = (v / c) f_{carrier} \quad (1)$$

Where v is the velocity of the mobile terminal, c is the speed of light or electromagnetic wave in the air, and $f_{carrier}$ is the carrier frequency of the signal transmission. The worst-case Doppler shift value from equation (1) for relative speed 125 km/hr (~ 35 m/s) would be ~ 700 Hz for operation at the 6 GHz upper limit specified by the standard.

$$f_{doppler} = (35/3 \times 10^8) \times 6 \times 10^9 = 700 \text{ Hz}$$

In our simulation the "low value" a carrier frequency $f_{carrier}$ of 3.5 GHz (a mid- point in the 2- 6 GHz frequency range) and a mobile speed v of 20 km/hour (6 m/second), the Doppler frequency is ~ 70 Hz, and the "high value" Doppler shift corresponding to the operation at 3.5 GHz for v of 120 km/hour is ~ 400 Hz.

In the simulation, the channel has been modeled as a Multipath Rayleigh fading channel with additive white Gaussian noise (AWGN), at Simulink multipath fading box the calculated Doppler shift has been inserted.

3.3. WiMAX receiver model

The receiver implementation is an inversion of all the transmitter functions with addition of channel estimation and equalization parts. Several important receiver functions have a large impact on receiver performance. These include carrier tracking, frame synchronization and channel estimation. Of these, only the channel estimation functions were modeled in this simulation. First, a receiver model was constructed that reverses all of the elements of the transmitter, and its performance was validated using the AWGN channel. Second Multipath and Doppler shifts introduced into the channel model after implementation of receiver channel estimation and equalization functions. Figure 4 shows the initial receiver model incorporated into the context of an end-to-end simulation.

First extract the data symbols from the OFDM waveform. Then we demodulated the QPSK waveform, Deinterleave, decode (first Viterbi, then Reed Solomon) and finally reverse the bit scrambling operation of the transmitter. Simulation performed using AWGN channel to predict initial accuracy and ensure accessibility. It was in agreement with the published results [10].

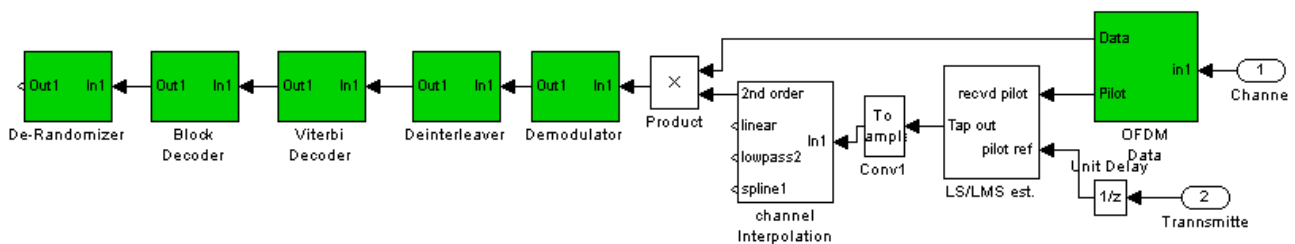

Figure 4. MATLAB Simulink WiMAX OFDM receiver

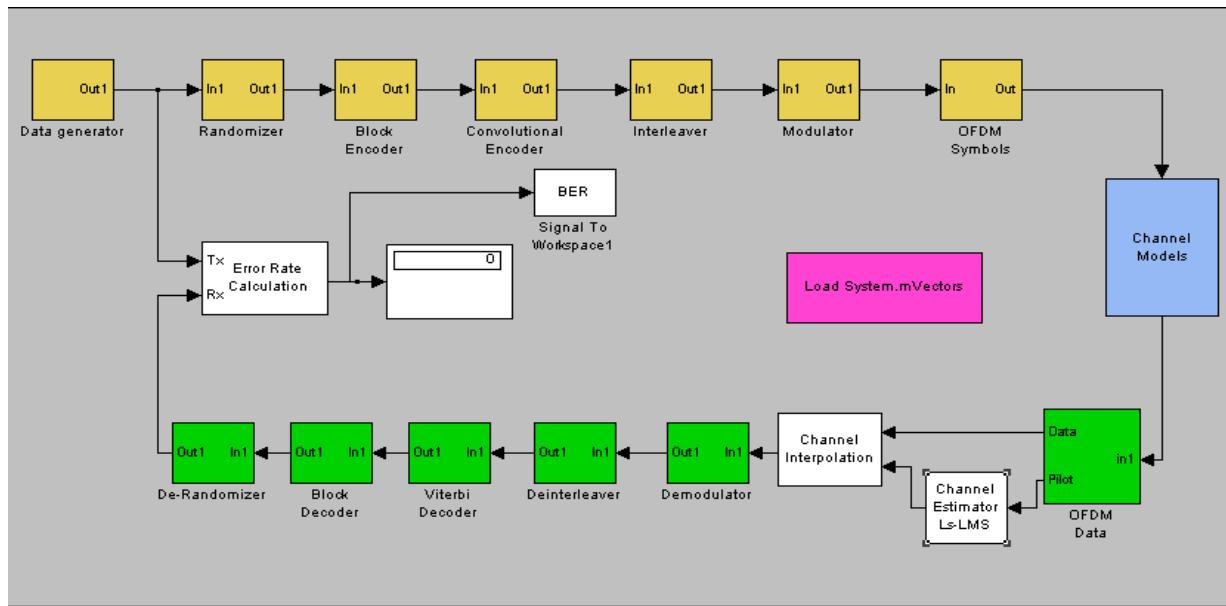

Figure 5. WiMAX End-to-End Simulink Model

3.4. channel estimation and equalization model

The channel estimation based on comb type pilot arrangement is studied through different algorithms for both estimating channel at pilot frequencies and interpolating the channel. The estimation of channel is based on LS and LMS while the channel interpolation is done using linear interpolation, second order interpolation, low-pass interpolation, and spline cubic interpolation. The channel estimation and Least mean-square (LMS) equalizer subsystems in SIMULINK are shown in figure 6, and 7 respectively. LMS algorithm is for adaptive FIR filtering of input signal. The effect of the different interpolation approaches on LS and LMS were tested. Also two cases with two different Doppler shifts which mean different relative velocities (high and low) applied to the system.

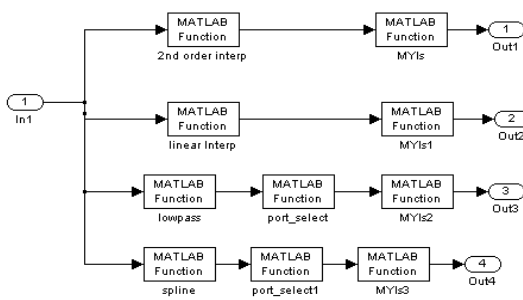

Figure 6. Channel estimation subsystem implemented in SIMULINK as MATLAB functions

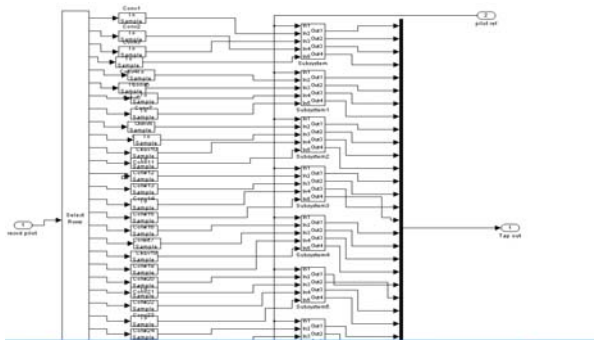

Figure 7. LMS subsystem in SIMULINK

4. RESULTS&DISCUSSION

We have simulated the proposed scheme for WiMAX communication system specifications. The AWGN and Multipath and Doppler shift channel models are used as testing environment.

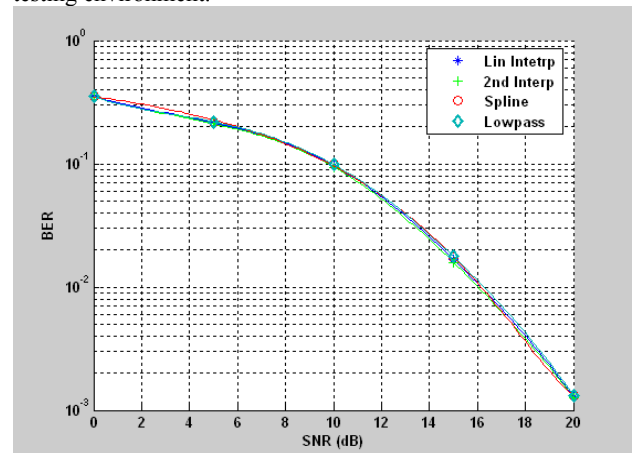

Figure 8. BER vs. SNR in dB for LS various interpolation criteria in fixed conditions

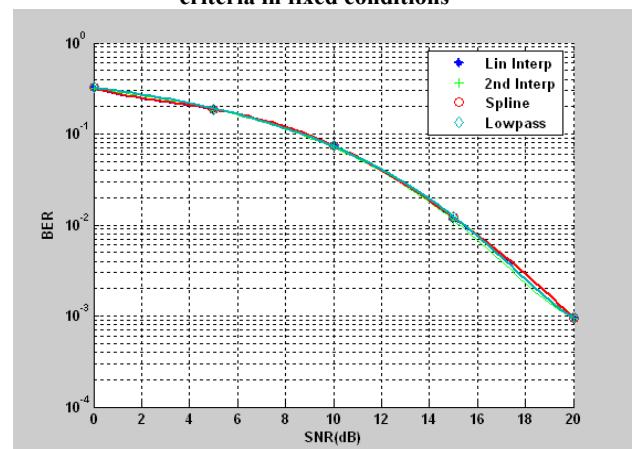

Figure 9. BER vs. SNR in dB for LMS with various interpolation criteria in fixed conditions

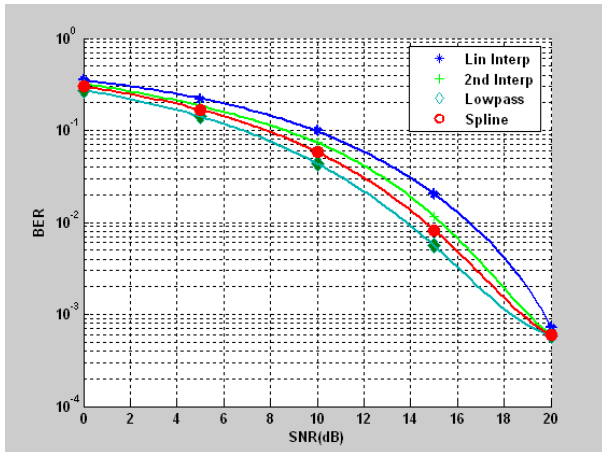

Figure 10. BER vs. SNR in dB for LS with small Doppler shift (low relative velocity)

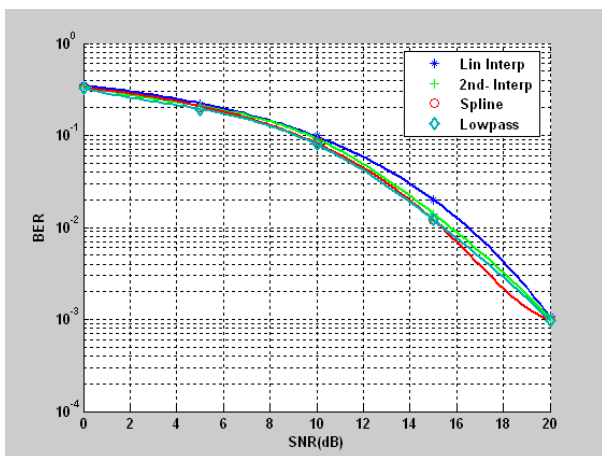

Figure 11. BER vs. SNR in dB for LMS with small Doppler shift (low relative velocity)

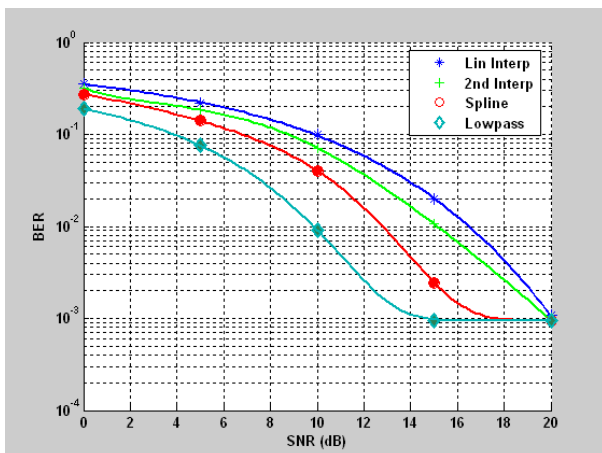

Figure 12. BER vs. SNR in dB for LS with high Doppler shift (high relative velocity)

Comparing the performances of all schemes by measuring bit error rate versus SNR with setup as shown in figure 5 the results are shown in figures 8 to 13. From figures 8 and 9, Channel estimation based on LS algorithm, with the linear interpolation, the second order interpolation, the spline cubic interpolation and the low-pass interpolation, respectively perform about the same as LMS algorithm in fixed condition. It is also shown that the performance among the comb-type estimation techniques usually ranges from the best to the

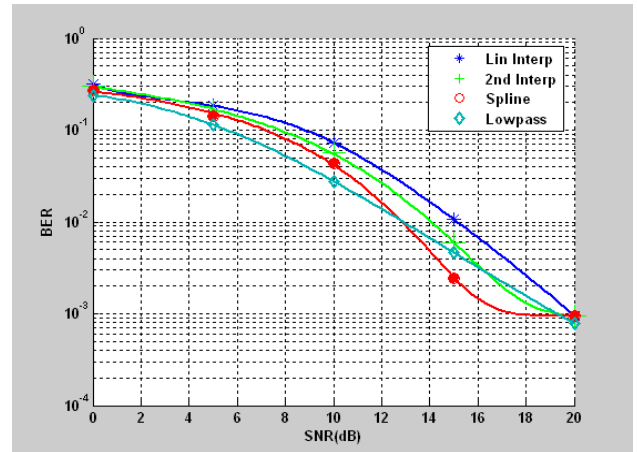

Figure 13. BER vs. SNR in dB for LMS with high Doppler shift (high relative velocity)

worst as follows, low-pass, spline cubic, second order, and linear. From figures (10, 12) and (11, 13) it is clear that LS estimator performance degrades at high relative velocity and LMS has better performance in mobile case. Also Even if the channel estimator's performance degraded with higher relative velocity, their mutual order in terms of Interpolation performance did not change. In general the channel estimator that performed the best in terms of lowest BER is the Lowpass interpolation algorithm.

This was expected since the comb-type pilot arrangement allows the tracking of fast fading channel and lowpass interpolation does the interpolation such that the mean square error between the interpolated points and their ideal values is minimized. Performance degradation can be tolerated for higher data bit rate for low Doppler spread channels although low-pass interpolation comb-type channel estimation is more robust for Doppler frequency increase [6]

5. CONCLUSION

WiMAX top level SIMULINK model with all system details has been implemented for simulation purpose. This paper has focused on channel estimation with different interpolation approaches for fixed/mobile OFDM system with parameters from WiMAX standards.

The Doppler shift had a greater impact on the relative performance between the different channel estimators and interpolation approaches. One of the most interesting properties that were discovered is the big impact the interpolation method has over the estimating method in case of mobile case. The result from the simulation is that the low-complexity LS method performs about the same for SNR as LMS which is more complex estimator, before Doppler shift but it has different behavior after that.

6. REFERENCES

- [1] IEEE. Standard 802.16-2004. Part16: Air interface for fixed broadband wireless access systems. October 2004.
- [2] IEEE. Standard 802.16e-2005 Part16: Air interface for fixed and mobile broadband wireless access systems—Amendment for physical and medium access control layers for combined fixed and mobile operation in licensed band. December 2005.
- [3] WiMAX Forum. Mobile WiMAX—Part I: A technical overview and performance evaluation. White Paper March 2006. www.wimaxforum.org.

- [4] WiMAX Forum. Mobile WiMAX—Part II: A comparative analysis. White Paper April 2006. www.wimaxforum.org.
- [5] Eugene Crozier and Allan Klein, “NLOS Optimization Outfits WiMax for Wide Coverage”, RTC Magazine Inc., March, 2005
- [6] Carin Omurcali, “Channel estimation and its effect on the performance in an OFDM system”, IR-SB-EX-0418, pp. 34-35, Royal Institute of Technology, May 2004
- [7] www.mathwork.com Recorded Webinar "From a Wireless Standards Document to an Executable Model using MATLAB and Simulink" July 14, 2005
- [8] “Channel models for Fixed Wireless Applications,” IEEE 802.16.3c - 01/29r4, 16 July, 2001
- [9] “Part 16: Air Interface for Fixed Broadband Wireless Access Systems” IEEE Std 802.16-2004
- [10] WiMAX Forum. WiMAX Forum Mobile System Profile 2006–07.