

# Assessing Variability in the Wideband Mobile Radio Channel

Steve M.R. Jones<sup>1</sup>, Khalid G. Samarah<sup>2</sup>, Yousif A. Dama<sup>1</sup>, Raed A. Abd-Alhameed<sup>1</sup>,  
Waleed Rasheed<sup>3</sup>, and E. Almahdi Elkhazmi<sup>4</sup>

<sup>1</sup> Mobile and Satellite Communications Research Centre, Bradford University, BD7 1DP, UK

<sup>2</sup> Mutah University, Amman, Jordan

<sup>3</sup> College of Information Technology, Asra University

<sup>4</sup> The Higher Institute of Electronics, Bani Walid, Libya

s.m.r.jones@brad.ac.uk, r.a.a.abd@brad.ac.uk,  
kgsamarah@mutah.edu.jo, wali20012001@yahoo.com,  
Eaelkhazmi@hotmail.com

**Abstract.** An assessment of the performance of OFDM transmissions over the wideband mobile radio channel is reported. The simulation in MATLAB/Simulink is based on the CODIT channel model. The results show that BER deteriorates significantly as the mobile velocities increase from 0 to 30 m/s. Significant variability in the BER for a given channel type is quantified. For a given instance of the channel the standard deviation of the estimated BER is 20%, but when averaged over many separate instances of the same channel type, a standard deviation of 47% is found.

**Keywords:** wideband, CODIT channel model, OFDM, Doppler, BER.

## 1 Introduction

Whilst conventional mobile telecommunications systems delivered only speech and short text messages, systems must now compete to provide access to wide range of multimedia services. This requires the flexibility simultaneously to carry not only conventional digital voice signals and text but also broadband data, audio and video streams etc., and heralds a convergence of mobile telecommunications, broadcast and broadband wireless access systems. The required flexibility can be provided by an air interface employing orthogonal frequency division multiple access (OFDMA) schemes, as we see for example in the long-term evolution programme in 3GPP [1] and in WiMax [2].

To evaluate OFDM system performance correctly for the wideband mobile channel the simulation must model delay spread and Doppler characteristics realistically. However, difficulty arises when evaluating performance over the wide range of radio channel environments that there can be considerable variability of performance within any particular channel category.

A channel simulator [3], based on the RACE-CODIT model [4] was constructed in MATLAB-Simulink. The simulator provided for evaluation of OFDM performance for the range of channel environments listed in Table 1 for system parameters typical of an OFDM system dimensioned for the mobile channel and listed in Table 2. Typical outputs were bit error ratio (BER) curves versus signal-to-noise ratio (SNR) at each mobile velocity.

This paper describes work that was undertaken to evaluate the variability of performance that can arise amongst different instances of the same channel type, as defined for the CODIT wideband channel model. The paper is organised as follows: in Section II the CODIT channel model is briefly outlined; Section III describes the OFDM system simulator and presents some typical results; Section IV describes the analysis performed on the variability of the channel for a given environment; Section V presents the conclusions.

**Table 1.** Environment types

	<b>Channel Environment Type</b>
<b>Conventional cells</b>	Urban
	Suburban
	Rural
	Hilly Suburban
	Hilly Rural
<b>Microcells</b>	Dense Urban Linear Street
	Town Square LOS
	Industrial Area LOS
<b>Picocells</b>	Floor Cell in Building
	Corridors
	Large Room Cells
	Very Large Hall LOS & NLOS

## 2 The Codit Wideband Channel Model

The CODIT model describes the multipath wideband radio channel in terms of a time-variant impulse response. The response is considered to comprise a number of paths, each of which consists of one (potentially dominant) component plus 100 diffuse waves received within the same resolvable delay. The model creates impulse responses that have realistic power-delay and Doppler characteristics for the various categories of environment. This is achieved by stochastically assigning amplitude, delay, phase, and angle-of-arrival according to probability distributions that closely resemble the characteristics found in the large database of wideband measurements available to the RACE programme. Parameters for the probability distributions are specified for each environment. The impulse response is given by

$$h(t, \tau) = \sum_{i=1}^L E_{i_l}(t) E_{s_i}(t) \delta(t - \tau_i(t)) \tag{1}$$

with

$$E_{s_i}(t) = a_{i0} e^{j\phi_{i0}} e^{j\frac{2\pi vt}{\lambda} \cos \alpha_{i0}} + \sum_{j=1}^{100} a_{ij} e^{j\phi_{ij}} e^{j\frac{2\pi vt}{\lambda} \cos \alpha_{ij}} \tag{2}$$

where  $L$  is the number of paths;  $E_{i_l}$  describes the long-term and  $E_{s_i}$  the short-term path-amplitude variation;  $a_{i0}$  is normalised amplitude of the dominant wave and  $a_{ij}$  that of the diffuse waves, (the latter being drawn from a Rayleigh distribution of mean value  $\Omega_i$ );

$\alpha_{ij}$  indicates angle-of-arrival (AoA) of each wave;  $\phi_{ij}$  indicates initial phase;  $\lambda$  the carrier wavelength;  $v$  mobile velocity;  $t$  time;  $\tau_i$  is the mean delay of the  $i^{\text{th}}$  path, allocated with uniform probability up to the maximum delay for the channel type. The relative amplitude of the dominant and diffuse waves is determined according to a coherence coefficient  $m_i$ , so path amplitudes can be either Rayleigh or Rice distributed. Within each path, the dominant ray AoA is randomly assigned in  $[-\pi, \pi]$ , whilst the diffuse rays angles then have a normal distribution around this angle with standard deviation fixed at 0.15 radians. The long-term amplitudes and delays of each path vary slowly and sinusoidally with time, their independent periods related to mobile velocity. Further detail is given in [3]. Environment parameters are listed in Table 3.

**Table 2.** System parameters

Parameters	Values of Simulation
Guard Time ( $T_g > \tau_{\max}$ )	20 $\mu\text{s}$
Useful Symbol Time ( $T_u = 4.T_g$ )	80 $\mu\text{s}$
Symbol Duration ( $T_s = T_u + T_g$ )	100 $\mu\text{s}$
Sub-Carrier Frequency Spacing ( $f_{sc} = 1/T_u$ )	12.5 kHz
Bit Rate ( $R_b$ )	20 Mbps
No. Information bits ( $B_{info} = T_s R_b$ )	2000
Modulation Scheme	QPSK
Data Sub-Channels ( $N_d = B_{info} / \log_2(M)$ )	1000
System Channel Bandwidth ( $BW = N_d f_{sc}$ )	12.5 MHz
FFT Size (Number of Sub-Carriers) ( $N$ )	2048
Null Sub-Carriers ( $N_z$ )	1048
Sampling Time ( $t_s = 1/f_s$ )	39.063 ns
Carrier Frequency ( $f_c$ )	2 GHz
Parameters	Values of Simulation
Guard Time ( $T_g > \tau_{\max}$ )	20 $\mu\text{s}$
Useful Symbol Time ( $T_u = 4.T_g$ )	80 $\mu\text{s}$
Symbol Duration ( $T_s = T_u + T_g$ )	100 $\mu\text{s}$
Sub-Carrier Frequency Spacing ( $f_{sc} = 1/T_u$ )	12.5 kHz
Bit Rate ( $R_b$ )	20 Mbps
No. Information bits ( $B_{info} = T_s R_b$ )	2000
Modulation Scheme	QPSK
Data Sub-Channels ( $N_d = B_{info} / \log_2(M)$ )	1000
System Channel Bandwidth ( $BW = N_d f_{sc}$ )	12.5 MHz
FFT Size (Number of Sub-Carriers) ( $N$ )	2048
Null Sub-Carriers ( $N_z$ )	1048
Sampling Time ( $t_s = 1/f_s$ )	39.063 ns
Carrier Frequency ( $f_c$ )	2 GHz

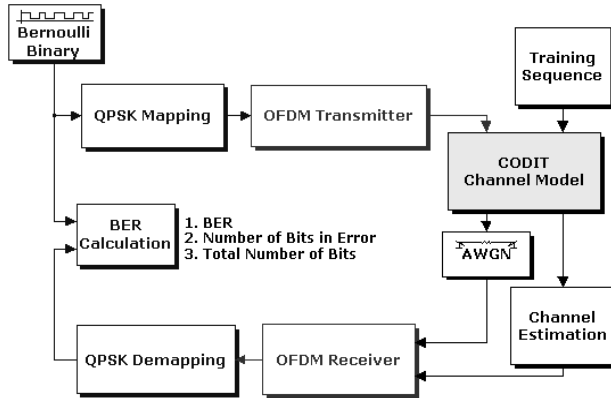

Fig. 1. OFDM Simulator

Table 3. Channel parameters used in the CODIT channel model

Channel Type	Scatterer	$\Omega_i$	$m_i$	$\tau_{max}$ ( $\mu s$ )	$\alpha_0$
Urban	1-20	[0.5-1.5]	1	2.4	$[0, \pi]$
Suburban	1	1	15	0	$[0, \pi]$
	2-6	[0.1-0.4]	[1-5]	15.8	$[0, \pi]$
Rural	1	1	25	0	$[0, \pi]$
Town Squares	1	1	25	0	$[0, \pi]$
	2-5	[0.05-0.8]	10	0.2	$[0, \pi]$
	6-10	[0.01-0.05]	1	0.2	$[0, \pi]$
Corridor	1	1	25	0	$\alpha_0 = [0, \pi]$
	2-5	[0.05-0.2]	5	0.12	All = $\alpha_0 + [0, \pi]$
	6-10	[0.01-0.05]	1	0.16	$[0, \pi]$

### 3 The OFDM System Simulations

The architecture of the simulator is shown in Figure 1. Random data are mapped to frequency-domain QPSK symbols, zero-padded and transformed into the time-series signal. The cyclic prefix (CP) is added. In order, correctly to simulate the effect of the Doppler spread, the channel impulse response is convolved with the transmitted sequence in the time domain and Gaussian noise added. The CP is stripped off, the received signal is transformed to the frequency domain. Ideal equalisation is assumed and applied so that the symbols can then be de-mapped using MMSE detection and compared with the transmitted sequence. The BER is then calculated.

*Typical Results:* We observe a significant deterioration of BER with mobile velocity as shown in Figures 2 and 3. In Figure 2, for the Urban channel the BER tends to a limit imposed by the intersymbol interference created as Doppler spread compromises the orthogonality of adjacent subcarrier spectra. Additional results were given in [5].

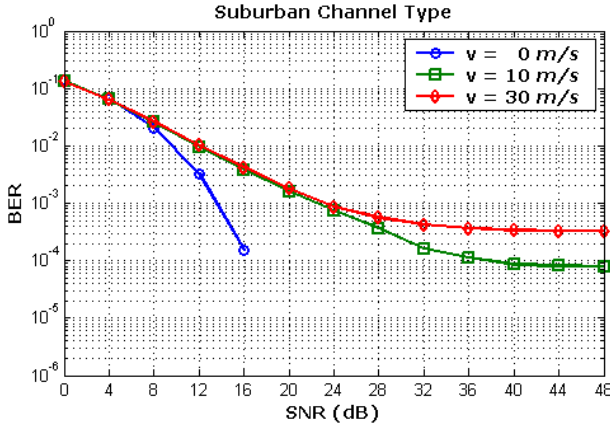

Fig. 2. BER vs SNR for the Urban Channel for velocities of 0, 10 and 30 m/s

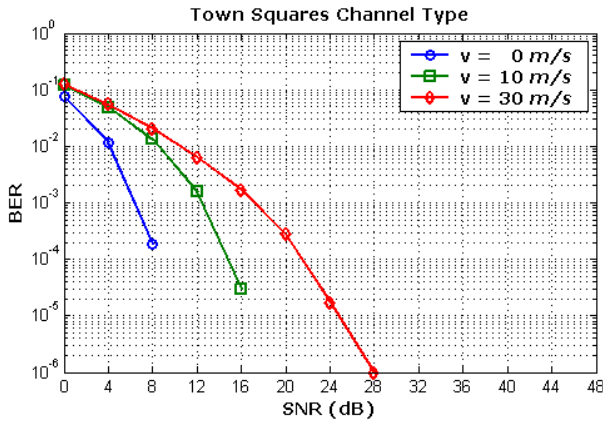

Fig. 3. BER vs SNR for the Town Square Channel for velocities of 0, 10 and 30 m/s

### 4 Variability within Given Channel Types

For a given instance of the channel, sufficient iterations are required to produce a stable BER estimate averaged over different examples of the noise. For any one instance of the channel, there are also variations as the path delays and diffuse rays vary. Finally, for any channel type, each instance of the channel is different (as in the real world) and produces significantly different BER. In order to characterise these variations, the simulation was run over lengthy periods of time. In the first instance, shown in Figure 4, the same seed for the channel random generators was used and BER values were collected over successive sections of the simulation. The probability density function (PDF) of the BER variations is narrow, with a relatively small standard deviation. In the second case, the simulation was run with different random

seeds for the channel and the PDF of BER is contrasted in Figure 5. Here it is apparent that the spread of values is much larger and attributable to variability within different instances of the same channel type. Normalising the standard deviations  $\sigma$  as a percentage of the mean BER  $\mu$ , for a SNR of 28 dB, gave:

$\frac{\sigma_{SNR=28dB}}{\mu_{SNR=28dB}} \times 100 = 20\%$	same seed
$\frac{\sigma_{SNR=28dB}}{\mu_{SNR=28dB}} \times 100 = 47\%$	different seeds

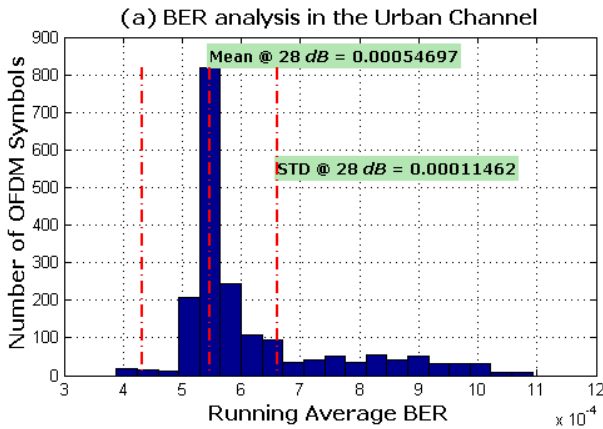

Fig. 4. PDF of BER for lengthy simulation for the same instance of the channel (same seed)

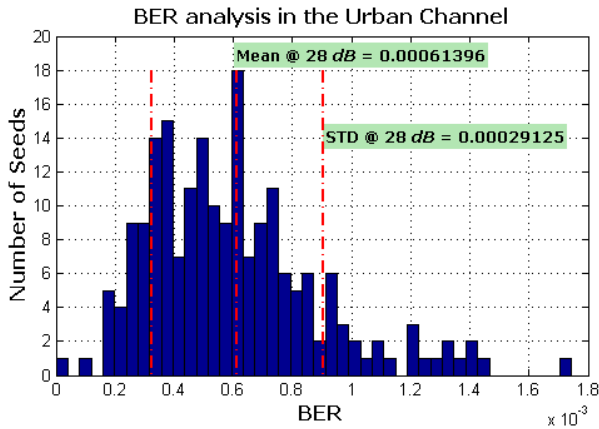

Fig. 5. PDF of BER for many instances of the same channel type (different seeds)

## 5 Conclusions

A detailed simulation of OFDM performance over the CODIT wideband mobile channel shows that the BER performance deteriorates significantly with mobile velocity. Variation of estimated BER over a lengthy simulation run was found to be of the order of 20% for a given instance of the CODIT channel, however when averaged over many instances of the same channel type, the variation was much larger, of the order of 47%.

**Acknowledgement.** Authors would like to thank (The National Organization for Scientific Research) [www.nasr.ly](http://www.nasr.ly). Tripoli. Libya.

## References

1. Dahlman, E., Ekstrom, H., Furuskar, A., Jading, Y., Karlsson, J., Lundevall, M., Parkvall, S.: The 3G Long-Term Evolution - Radio Interface Concepts and Performance Evaluation. In: IEEE 63rd Vehicular Technology Conference, VTC 2006, Spring, May 7-10, vol. 1, pp. 137–141 (2006)
2. Mobile WiMAX – Part II: A Comparative Analysis WiMax Forum (May 2006)
3. Samarah, K.G.: High Bit Rate Air Interface for Next Generation Mobile Communication Systems, University of Bradford PhD. Thesis (2007)
4. Andermo, P.G., Larsson, G.: Code division testbed, CODIT. In: 2nd International Conference on Personal Communications: Gateway to the 21st Century, Ottawa, Ont., Canada, October 12-15, vol. 1, pp. 397–401 (1993)
5. Samarah, K.G., Jones, S.M.R.: Assessment of High Bit Rate Mobile OFDM Systems Using the CODIT Channel Model. In: Proceedings of the European Conference on Antennas and Propagation, EUCAP 2006, Nice, France, November 6-10 (2006)