

Novel Analytical Delay Model and Burst Assembly Scheme for Wireless Mesh and Optical Burst Switching Convergence

Jihene Rezgui, Abdeltouab Belbekkouche, and Abdelhakim Hafid

Network Research Laboratory
University of Montreal, Canada
{rezguiji, belbekka, ahafid}@iro.umontreal.ca

Abstract. Wireless Mesh Networks (WMN) have attracted increasing attention from the research community as a high-performance and low-cost solution to last-mile broadband Internet access. In the other side, Optical Burst Switching (OBS) is a promising access technology that uses optical fiber with burst switching paradigm. In this paper, we propose a novel Metropolitan Area Network (MAN) architecture, called Optical Burst Wireless Mesh Architecture (OBWMA) which integrates WMN at the user access side and OBS at the core of the MAN. OBWMA aims to combine advantages of both WMNs and OBS networks, such as large coverage at low cost and bandwidth availability. We specify the details of the interconnection and the internetworking of WMNs and the OBS network in OBWMA. Moreover, we develop an analytical model to compute the end-to-end delay in OBWMA in order to support flow requests with delay constraints. Furthermore, we propose a Control Bridge (CB) that ensures Quality of Service (QoS) mapping at the border between the WMN and the OBS parts. Also, we propose a burst assembly scheme, called Adaptive Hybrid Burst Assembly scheme (AHBA). Simulation results using ns-2 demonstrate the feasibility of OBWMA and the validity of our analytical model.

Keywords: MAN, WMN, OBS, QoS, DiffServ, Wireless Optical Convergence.

1 Introduction

Metropolitan Area Networks (MANs) are public networks aimed to interconnect high-speed core networks (Wide Area Networks) and relatively low-speed access networks (Access and Local Area Networks). In the context of Next Generation Networks (NGNs), MANs are required to offer the following characteristics [1]: dynamic bandwidth provisioning, scalability, upgradability, efficient and flexible use of resources, Quality of Service (QoS) differentiation, reliability, high throughputs and short delays. Meanwhile, end-users are becoming more and more bandwidth hungry because of data, voice and multimedia applications that have grown exponentially over the past several years; these applications are expected to continue growing over the next years. Thus, a MAN architecture which connects the end-user

to the Internet, while supporting the increasing bandwidth demand and satisfying NGNs specifications, is needed today. In this paper, we study the integration of WMNs and OBS networks in a MAN architecture that takes into consideration the above requirements.

Wireless mesh networks (WMNs) have recently emerged as a promising technology for the next-generation wireless networks. A WMN consists of two types of nodes: Mesh Clients (MCs) and Mesh Routers (MRs). The MRs form an infrastructure which forwards the traffic between MCs and the Internet. In general, MRs have minimal mobility and operate just like a network of fixed routers, except being connected by wireless links through wireless technologies such as IEEE 802.11. A subset of the MRs is connected to the Internet (via wired or wireless links, e.g., 802.16 links); they are called gateways. A WMN has numerous benefits, such as the reduction of installation costs because only a few MRs may have cabled connections to the wired network [2]. Moreover, it has a large-scale deployment since it is a multi-hop network that offers long distance communications through intermediate nodes. Another considerable advantage is the reliability due to the redundant paths between each pair of nodes in the network.

WMNs have been widely deployed to deliver wireless services for a large variety of applications, such as broadband home networking, community and neighborhood networking, metropolitan area networks, health and medical systems, etc. Some of the WMN features are to support ad hoc networking: capability of self-forming, self-healing, and self-organization. Also, a WMN allows multiple types of network access, compatibility and interoperability with existing wireless networks and multi-channel multi-radio operation. This last feature is very important because it increases the network capacity. Indeed, IEEE 802.11 offers multiple non-overlapping channels (e.g., 3 and 12 channels for 802.11b and 802.11a, respectively). Each node could be equipped with multiple radios which increases significantly the throughput. Moreover, the integration of WMNs with other networks, such as the Internet, cellular, IEEE 802.16 and sensor networks, can be accomplished through the gateway and bridging functions in the MRs.

In the other side, Wavelength Division Multiplexing (WDM) is an attractive technology to support the huge amount of bandwidth required by the core of the MAN network. It uses the potential capacity in optical fibers that contains many wavelengths able to carry (potentially) tens of Tbps using statistical multiplexing. This potential requires good switching technology to efficiently exploit it. OBS (Optical Burst Switching) [3] is a good switching paradigm candidate to fill this need. It has received an increasing interest from researchers over the last several years since it presents a good tradeoff between traditional Optical Circuit Switching (OCS) and Optical Packet Switching (OPS). OCS is relatively easy to implement but suffers from poor bandwidth utilization and coarse granularity; OPS has a good bandwidth utilization and fine granularity but suffers from complex implementations because of the immaturity of the current technologies, such as optical buffers and ultra fast optical switches [3].

In OBS networks, data packets with the same destination are aggregated in bursts of variable lengths at the ingress node; this process is called Burst Assembly. After burst assembly, a Control Packet (also, called Burst Header Packet) is sent, using a dedicated control wavelength, from source to destination in order to reserve the

required resources along a lightpath. This control packet is subject to Optical-Electric-Optical (OEO) conversions at each core node (OBS switch) where it receives an appropriate processing to make resource reservation for its data burst. After a delay called Offset Time (OT), the corresponding data burst is sent, on one of the data wavelengths, through the same lightpath without any buffering requirement inside the OBS network. The huge bandwidth and the high flexibility of OBS, added to its simplicity of implementation (using the existing infrastructure), efficient utilization of resources, QoS and differentiated services support, make OBS an excellent candidate to play the role of a core network in a next generation MAN.

Therefore, the integration of WMNs and OBS networks in a novel architecture is an interesting idea to explore. In this paper, we propose a novel MAN architecture, called Optical Burst Wireless Mesh Architecture (OBWMA), which is composed of WMNs at end-user access part and an OBS network at the core part of the MAN. Whereas WMNs offer coverage to the end-users, the OBS network connects several WMNs to the Internet using its huge bandwidth capacity. The operation of OBWMA and the internetworking between WMN and OBS is based on the Internet Protocol (IP) which is adopted as the basis of the NGNs. Our contributions in this paper can be summarized as follows: (a) A novel MAN architecture (OBWMA) integrating, for the first time, multi-channel multi-radio WMNs and OBS networks; (b) An analytical model to compute end-to-end delay in OBWMA; (c) A Control Bridge (CB) which ensures QoS mapping between WMN and OBS; and (d) A novel Adaptive Hybrid Burst Assembly scheme (AHBA).

The paper is organized as follows: Section 2 presents related work. Section 3 describes OBWMA architecture. In Section 4, an analytical model to compute the end-to-end delay inside OBWMA is presented. In Section 5, we present the proposed control bridge and burst assembly scheme. Section 6 presents simulation and analytical results. Finally, Section 7 concludes the paper.

2 Related Work

The concept of wireless and wired convergence is becoming more and more attractive in both academia and industry communities. This trend for reducing the gap between the wireless and the wired domains is motivated by the adoption of NGNs as a framework solution for the next generation Internet that recommends this kind of convergence. In [4], Fixed Mobile Convergence technology (FMC) is proposed. FMC provides seamless services via a combination of fixed (optical)/wireless broadband and wireless access network technologies. The authors in [5] proposed integrated optical and wireless services in the access network; they defined several optical wireless integration scenarios. The integrated network performance has been evaluated through simulations. Their results demonstrate that optical wireless integration decreases access point complexity, increases the capacity of wireless networks and promotes mobility in access networks. Decreasing access point complexity is achieved by integrating the optical access system (Optical Line Terminals (OLTs) of Passive Optical Network (PON)) and wireless base stations at the edge node. The authors in [6] studied a system that integrates GEneralized Passive Optical Network (GEAPON) OLTs and WiMAX base stations at the edge nodes; the proposed system extends the WiMAX antenna using the GEAPON optical link and the Optical Network Unit (ONU). The ONU

aggregates the incoming requests from the WiMAX subscriber stations and sends them towards the edge node. When the requests reach the edge node, the OLT interacts with the WiMAX base station to allocate the necessary bandwidth so that the subscribers get the required QoS when their traffic passes through the WiMAX and PON networks. The authors in [7] proposed an integrated network architecture composed of GEAPON and WiMAX (802.16d/e) to reduce the capital and operational expenditure (CapEx and OpEx). To validate their architecture, they studied the QoS support and the wireless network throughput.

We note that Passive Optical Network (PON) is often used in the context of wireless and optical convergence (from the optical side). However, PON uses Time Division Multiplexing (TDM) and often tree topology. Hence, we believe it is not appropriate to use PON as a core network; instead, it is more appropriate to use PON as an access network in the context of Fiber-To-The-Home (FTTH) paradigm.

The authors in [8] proposed a simple paradigm based on connecting WLAN and OBS networks. They investigated the use of the two wireless access mechanisms: DCF and PCF; and different packet sizes without more details. In [9], the authors performed a simulation based study of TCP performance over an architecture composed of OBS at the core network and 802.11 at the access network. We believe that the contributions in [8] and [9] are in the right direction since they show the interest of interconnecting 802.11 and OBS technologies. However, they remain in the stage of *proof of the concept* without exploring the interconnection concept deeply and without a global view of the performance of the converged network (the wireless and the optical parts). Moreover, to the best of our knowledge, this is the first time that the integration of multi-channel multi-radio WMNs and OBS networks is studied.

3 The Proposed Architecture

Fig. 1 shows the structure of the proposed architecture where a number of WMNs (of medium size) are interconnected between them and connected to the Internet through a core OBS network. In fact, in this architecture, the gateways (one or more) of each WMN are connected to an OBS edge node. For a given OBS edge node, the WMNs connected to it are called *home WMNs* while the other WMNs (in OBWMA) are called *foreign WMNs*. The connection between an OBS edge node and their home WMNs could be performed using a dedicated device or simply using a wired connection. This point is discussed in subsection C.

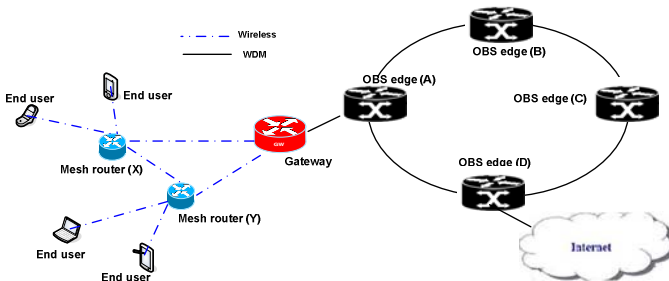

Fig. 1. Overview of OBWMA

3.1 The WMN Part

The first key part of OBWMA is the WMN part (see Fig. 2) where the MRs (e.g. MR_3, MR_{17}) aggregate and forward the traffic from their MCs to the gateways. The MRs communicate with each other to form a multi-hop wireless network. This wireless network forwards the user traffic to the gateways (e.g. P_1 and P_2 in Fig. 2) which are connected to the Internet and other WMNs in OBWMA via the OBS core network.

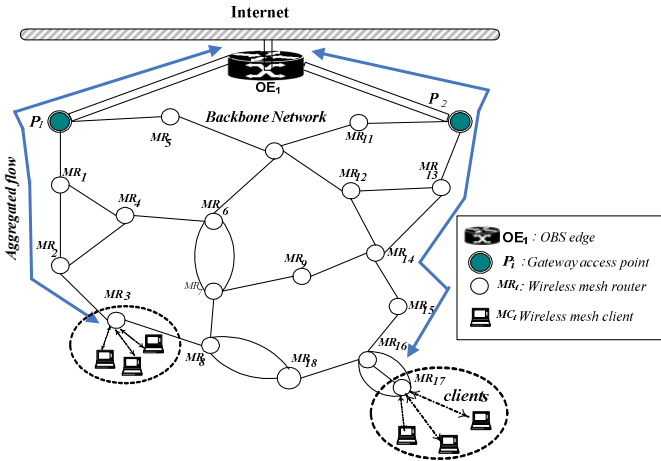

Fig. 2. A schematic sketch for WMN over OBS

A WMN allows mesh nodes or gateways to communicate with each other without being routed through a central switch point, eliminating centralized failure and providing self-healing and self-organization. Although decisions on traffic are made locally, the network can be managed globally. Furthermore, since each MR may aggregate traffic flows for a large number of mobile MCs, the aggregate traffic load of each MR changes very rarely. In WMN infrastructure, some MRs are also equipped with a gateway capability through which they interface with the wired network (OBS core network in our case). In such networks, traffic is mainly routed by the WMN wireless backbone between the MCs and the Internet through the gateways. In addition, the traffic distribution is typically skewed as most of the user traffic is directed to/from the wired network.

Providing QoS in the wireless part depends upon how well the network capacity is estimated. This estimation is difficult to obtain because, compared to wired networks, the links in WMNs are inherently shared (because of interferences) and difficult to isolate. This fact makes the performance of WMNs difficult to control. It is crucial to control the traffic to guarantee the QoS requirements (e.g., end-to-end delay) [10]. The reason is that interferences among links cause performance degradation, e.g., two interfering links that are active simultaneously often provide much less throughput than two separated links. To guarantee QoS, OBWMA accepts a new flow request only when the required flow end-to-end delay in WMN part is satisfied (see section 5).

Architecture and routing protocols mechanisms of WMNs have been extensively studied in literature [2]. In OBWMA, we use DSDV [11] as the routing protocol of the wireless Part. It is worth noting that any other routing protocol for WMNs can be used.

3.2 The OBS Part

The OBS core network of OBWMA is a ring network composed of a set of OBS edge/core nodes. In fact, each OBS node in the core network can receive and send the traffic of its home WMNs (which is the role of an OBS edge node) and route the transit traffic of foreign WMNs (which is the role of an OBS core node). The ring topology is widely used in MANs because of its characteristics of failure recovery and scalability. However, other kinds of topologies, such as mesh and regular topologies could be used for OBWMA.

Burst assembly is a key mechanism in the OBS network where incoming packets from the client networks with the same destination are aggregated in data bursts according to some criteria, such as QoS (e.g., delay). There exist mainly three schemes of burst assembly [12]: (a) time-based schemes that use a maximum time threshold before forming the burst; (b) size-based schemes that use a maximum burst size threshold before forming the burst; and (c) hybrid schemes that use both time and size thresholds. For OBWMA, we propose an adaptive hybrid scheme, called Adaptive Hybrid Burst Assembly scheme (AHBA) which uses adaptive time and size thresholds to allow QoS mapping between WMN and OBS, i.e., the translation of QoS constraints from the wireless domain (represented by the WMN) to the optical domain (represented by the OBS network). AHBA is discussed in Section 5.B.

In the OBS network, resource reservation has an end-to-end scope and it is performed by control packets which are sent on dedicated control wavelength(s). Whereas, generally, in OBS networks one-way reservation is adopted to minimize the end-to-end delay, two-way reservation allows preventing burst losses inside the OBS network at the cost of an increase of the end-to-end delay. For OBWMA, we adopt the one-way resource reservation scheme to alleviate the increase in end-to-end delay.

Wavelength assignment has an important impact on OBS networks, especially, when wavelength converters are sparse or not used at all, at the core nodes. In fact, wavelength converters are expensive and have not yet reached their technological maturity. Thus, we do not use wavelength converters in the OBS core network.

In OBS networks, Shortest Path routing (SP) is often used since it ensures optimal resource utilization. However, adaptive and multipath routing could be used to improve the burst loss rate performance. Nevertheless, adaptive and multipath routing approaches suffer from issues, such as routing path loops, out-of-order delivery and jitter [13]. Hence, we adopt SP routing for the OBS core network of OBWMA.

3.3 WMN and OBS Interconnection and Internetworking

The interconnection of WMNs and the OBS core network in OBWMA is ensured by simple wired connections between the gateways of WMNs and the OBS edge nodes.

This interconnection is performed in the electronic domain. It is worth noting that the storage capability of the electronic domain makes it omnipresent in WMN gateways and OBS edge nodes. However, this interconnection has to be carefully provisioned with bandwidth in order to prevent this part of the network from forming a bottleneck. Since narrowing the gap between wireless and optical worlds is one of the objectives of NGNs, we can use optical fibers for the wired connection. Nevertheless, electronic domain will always be present in gateways and OBS edge nodes because of the lack of optical buffers in one hand, and the advanced buffering technology of electronic domain in the other hand. Besides, a sophisticated device which incorporates a gateway with an OBS edge node in a single device could be conceived. Hence, this device will contain wireless, electronic and optical compartments. For economical and simplicity of realization reasons, we propose to use, exclusively, copper-based wired connections between gateways and OBS edge nodes in OBWMA. In fact, copper-based connections are cost effective and could be used with the existing WMN and OBS equipments, namely, gateways and OBS edge nodes.

The internetworking between WMN and OBS is based on the Internet Protocol (IP) which is designated to be the cornerstone of the operation of next generation networks. Fig. 3 shows the protocol stack of OBWMA and Fig. 4 shows the packet flow inside it. In Fig. 3, we can see that the protocol stack of OBWMA is composed of the protocol stacks of WMN and OBS. Specifically, 802.11 protocol is responsible for the operation of the WMN part MAC layer while the OBS protocol is responsible for the operation of the OBS part.

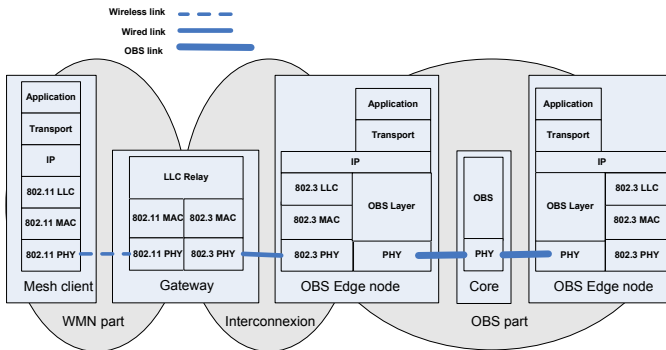

Fig. 3. The protocol stack of OBWMA

The interconnection between WMN and OBS parts is ensured by the 802.3 protocol. Hence, when the user data traverses OBWMA from end to end, it passes through the WMN part MAC layer as a 802.11 frame. Then, at the interconnection MAC layer it becomes a 802.3 frame. Finally, it passes the OBS part layer two as a data burst, before becoming again a 802.3 frame at the MAC layer of the OBS egress node (see Fig. 4).

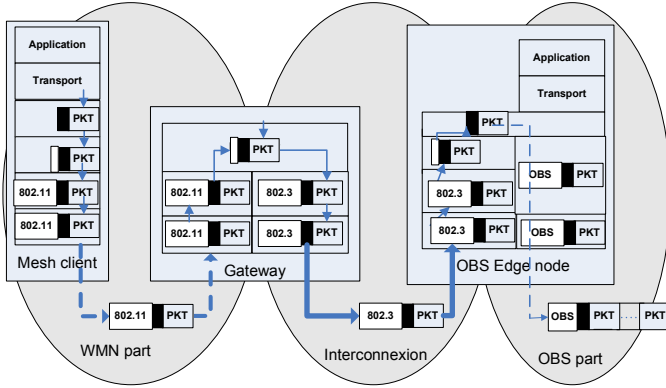

Fig. 4. Packet flow through the WMN and the OBS parts

4 End-to-End Delay Performance Model

As a next generation MAN network, OBWMA has to provide QoS guarantee capability. End-to-End delay is an important QoS constraint, especially, for delay-sensitive traffic. To deal with this constraint, we propose an analytical model to compute end-to-end delay in OBWMA. We characterize the traffic as Poisson process with mean packet arrival rate λ_i packets/s for each node i in the network (WMN or OBS node). It is well known that the combination of two or more Poisson traffics is Poisson traffic. For example, if a Poisson traffic A with mean packet arrival rate λ_A is combined with a Poisson traffic B with mean packet arrival rate λ_B the resulting traffic is still Poisson but with mean packet arrival rate $\lambda_A + \lambda_B$. Hence, if we suppose that the end-users traffic is Poisson, the incoming traffic in intermediate wireless MRs, gateways and OBS edge nodes is always Poisson. Furthermore, we assume that the packet size in WMNs is exponentially distributed with mean L and the maximum burst size in the OBS part is B .

4.1 End-to-End Delay in WMN

Before transmitting a packet, each node in a WMN counts a random timer which is exponentially distributed with mean Backoff duration $\frac{1}{\xi}$. The average service time of a mesh router MR_i , noted b_i , using channel $k \in \{1..NC\}$ is expressed as follows:

$$b_i = \frac{\frac{1}{\xi} + L}{1 - INTER_i} \tag{1}$$

where θ_k is the bandwidth capacity of k^{th} channel and $INTER_i$ is the interference ratio representing interferences between MR_i and its neighboring Mesh Routers (MRs).

In the case of no interferences,

$$INTER_i = 0, \quad (2)$$

If interferences exist, we consider that all interfering MRs have the same probability to access the medium. In this case:

$$INTER_i = \frac{L}{\theta_k} \times \left(\sum_{j \in N_{ct}} \lambda_j \right), \quad (3)$$

where λ_j is the packet arrival rate in a MR_j , and N_{ct} is the set of MRs that can contend for channel k . It is worth noting that $INTER_i$ is always in the range $[0, 1]$, since when it reaches value 1, the average service time tends to infinity; in this case, the majority of packets are dropped due to the high level of interferences.

The end-to-end delay for each path in the WMN part is determined by computing delay at each intermediate MR as follows:

$$d_{WMN} = \sum_{i \in PATH} b_i \quad (4)$$

where $PATH$ is the set of the nodes in the end-to-end path from the MC to the gateway.

4.2 End-to-End Delay in OBS

The delay in the OBS part is mainly composed of the assembly delay (at the edge node), noted d_a , and the offset time delay, noted d_o . The offset time d_o is the delay that separates the transmission of the control packet and the transmission of its data burst. This delay is useful to compensate the processing and the queuing time of the control packet at each intermediate node. Otherwise, the data burst could reach and surpass its control packet, in which case, it will be dropped since no resources have been reserved for it at this part of the OBS network. If AHBA scheme is used (see Section 5.B), a burst is formed if its length reaches size B or if the maximum assembly time T_a is reached. Hence, the average number of packets in a burst at an OBS edge node e is:

$$N = \min\left(\left\lfloor \frac{B}{L} \right\rfloor, \lfloor \lambda_e T_a \rfloor\right) \quad (5)$$

The WMN packet number p in the assembly process at the OBS edge node e , will undergo delay T_p in average, where T_p is given by:

$$T_p = \frac{(N-1) - (p-1)}{\lambda_e} = \frac{N}{\lambda_e} - \frac{p}{\lambda_e} \quad (6)$$

and the average assembly delay is:

$$d_a = \frac{1}{N} \sum_{p=1}^N T_p = \frac{N}{\lambda_e} - \frac{1}{N\lambda_e} \sum_{p=1}^N p = \frac{1}{2\lambda_e} (N-1) \quad (7)$$

Therefore, the mean OBS delay is:

$$d_{OBS} = d_a + d_o \tag{8}$$

where d_o is the sum of control packet queuing and processing times (at each intermediate node). Hence, we can estimate d_o if we can estimate the mean number of hops in the OBS part of OBWMA. Since the traffic in WMN is, generally, destined to/from the Internet, we can estimate the mean number of hops in the OBS core network. This is performed by computing the mean number of hops between the OBS edge node (or nodes) connected to the Internet and the other OBS edge nodes.

The end-to-end delay in OBWMA (i.e., the delay that a packet undergoes from the MC in the WMN part to the OBS egress node connected to the Internet) is calculated as follows:

$$d_{OBWMA} = d_{WMN} + d_{OBS} \tag{9}$$

5 Quality of Service Provisioning

Quality of service (QoS) provisioning is a mandatory functionality for NGNs. For this reason, we propose a QoS provisioning mechanism for OBWMA. This mechanism operates at the border between the OBS and WMN parts of the network. It is based on service differentiation. For service differentiation, and without loss of generality, we consider two classes of traffic: (a) Class of service 1 with quality of service requirements (e.g., delay); and (b) class of service 2 with no QoS requirements (best-effort service). We suppose that user flow requests (at MCs) come with their classes of service (class-1 or class-2) and their maximum end-to-end delays (Δ_{delay}). In addition, the flow request packet contains a field for accumulated delay in the WMN part d_{WMN} . d_{WMN} is updated at each intermediate WMN node. After the flow request is accepted, the 802.11 frames in the WMN part, the 802.3 frames in the interconnection part and the control packets in the OBS part contain a field for the class of service. This field takes value 1 for class-1 and value 2 for class-2. Fig. 5 shows the main fields of the flow request packet.

Source	Destination	Class-i	Δ_{Delay}	d_{WMN}
--------	-------------	---------	------------------	-----------

Fig. 5. Main fields of the flow request packet

5.1 The Control Bridge

In OBWMA, flow requests arrive from the WMN part to the OBS core network with end-to-end delay QoS requirements. In this paper, we consider only end-to-end delay, however, other QoS constraints could be considered (e.g., loss rate). Whenever the OBS edge node receives a flow request, it checks its class of service. Flows of class-1 should have to be accommodated with firm guarantees of QoS constraints but flows

of class-2 could be accommodated with the available resources and without guarantees of QoS constraints. To do so, we propose a Control Bridge (CB) which ensures QoS (delay) mapping between the two parts of the network. Fig.6 depicts the architecture of the proposed CB. It has two interfaces connecting the OBS edge node and the 802.11 gateway. The CB is located at the OBS edge node and has a global view of the state of burst assembly buffers.

For QoS mapping, we propose a novel burst assembly scheme (AHBA) with the main objective of realizing the mapping of delay constraints between WMN and OBS.

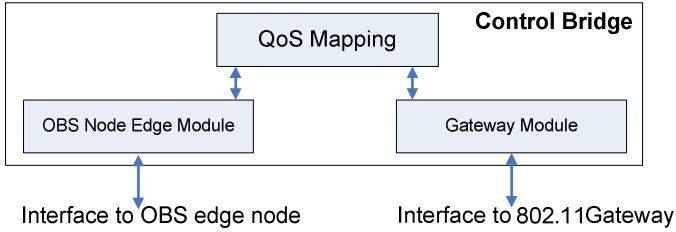

Fig. 6. Control Bridge Architecture

5.2 Adaptive Hybrid Burst Assembly Scheme

For the burst assembly process, we suppose that each OBS edge node has one buffer for each other OBS edge node destination and each class of traffic. Hence, each assembly buffer is identified by (destination, class of service) where destination is the destination OBS edge node and class can take values 1 or 2. Adaptive Hybrid Burst Assembly (AHBA) is a burst assembly scheme which takes into consideration two parameters: (1) Maximum Assembly Time (MAT); and (2) Maximum Burst Size (MBS). In addition, using AHBA, the CB has the ability to act directly on the assembly buffers by tuning or fixing their parameters (e.g., MAT). Indeed, parameters MAT and MBS for traffic of class-2 are fixed. This is done by fixing the burst size to a suitable value (e.g., 10KB) and then fixing assembly time to a reasonable value. The assembly time has to prevent excessive waiting time for class-2 traffic packets in the assembly buffer when the arrival rate of these packets is very low. Generally, this will result in fixed (class-2) bursts size inside the OBS network, which is a suitable property for OBS networks performance [14]. For class-1 traffic, the CB could tune the maximum assembly time of a class-1 assembly buffer to meet the quality of service requirement of a flow request in terms of end-to-end delay. Hence, upon the receipt of a class-1 flow request, the CB checks whether the corresponding assembly buffer could satisfy its end-to-end delay constraint. If it is the case, the flow request could be accommodated; otherwise, the CB tries the possibility of tuning the assembly time of the corresponding class-1 traffic assembly buffer in order to meet the delay requirement of the flow request. Noting that a buffer assembly time could be decreased for a given flow request but it could not be increased again only after the end of this flow. To compute the delay of the flow request, the CB extracts the required end-to-end delay noted Δ_{delay} and the WMN delay d_{WMN} from the flow

request packet. Then, the CB computes the OBS delay d_{OBS} using Eq. 8. The sum of d_{WMN} and d_{OBS} must be less or equal Δ_{delay} :

$$d_{WMN} + d_{OBS} \leq \Delta_{delay} \tag{10}$$

Otherwise, the CB tries to decrease the assembly time of the corresponding buffer by decreasing the maximum assembly time T_a . However, excessively decreasing T_a could result in forming data bursts of size near to that of an IP packet. This could eliminate the advantage of statistical multiplexing of the OBS core network and degrades its performance in terms of resource utilization. To tackle this issue, we introduce a new parameter, called MINimum Burst Size (MINBS), which is used to guarantee a minimum burst size. MINBS could be expressed as a multiple of an IP packet size L , e. g.: $MINBS = 3 \times L$, which means that the minimum number of IP packets in a burst is 3. Thus, Eq. 5 becomes:

$$N = Max(Min(\lfloor \frac{B}{L} \rfloor, \lfloor \lambda_e T_a \rfloor), MINBS) \tag{11}$$

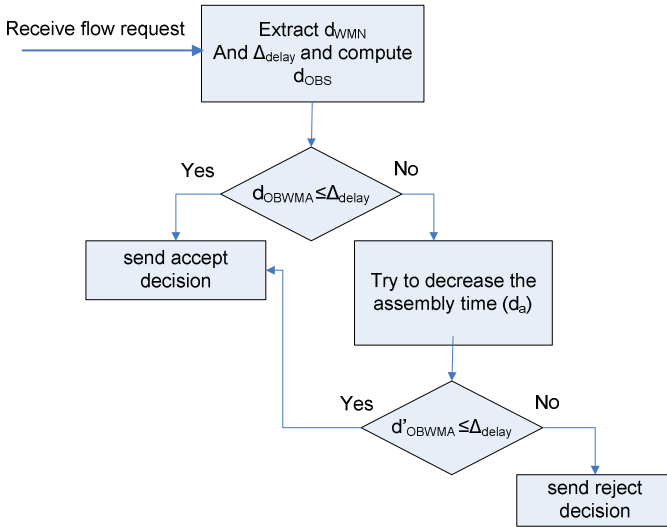

Fig. 7. The operation of AHBA

If a flow request delay requirement could not be met by decreasing the assembly delay d_a , this request is simply rejected, and a reject message is sent back to its source node in the WMN part. Fig. 7 shows the operation of AHBA.

It is worth noting that decreasing burst assembly time for a given flow and increasing it again at the end of this flow could increase the jitter of other flows in the network. However, this variation in the jitter is controllable and could be calculated; it is simply the difference between the assembly times before and after decreasing or

increasing the maximum assembly time T_a . In addition, the value of the jitter could be sent to the corresponding destination OBS node, each time the maximum assembly time is increased or decreased. However, this is out of the scope of this paper.

6 Numerical Results

In this section, we conduct simulations using ns-2 simulator [15] and present numerical results of the proposed delay analytical model to evaluate the performance of OBMWA. Our goal is to: (a) validate the operation of OBMWA, especially, the interconnection of the WMN part and the OBS part using ns-2 simulator; (b) evaluate the proposed analytical end-to-end delay model and compare it to simulation results of the end-to-end delay; and (c) measure the impact of varying the maximum assembly time, the IP packet size in the WMN part and the burst size in the OBS part. We consider only end-to-end delay as the main metric in OBMWA.

We use the topology illustrated in Fig. 8 to perform simulations where real-time traffic flows arrive at each wireless MR according to Poisson process. The traffic load expressed in the figures is the ratio [utilized bandwidth/ bandwidth capacity (with no traffic in the network)] at MR 1.

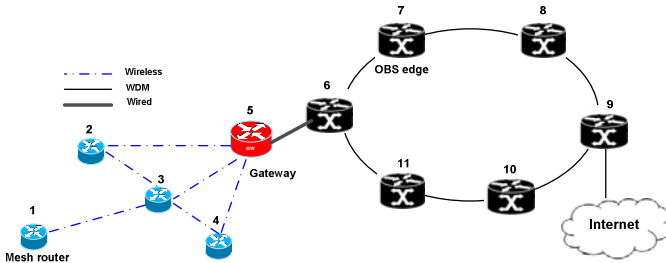

Fig. 8. Simulations topology

For the WMN part, the radio transmission range r takes one of the following values: 150 meters, 200 meters and 250 meters and the transmission interference R of each wireless station is 550 meters. Also, we fix the WMN packet size to 1000 KB unless stated otherwise.

For the OBS part, we assume that each single fiber link is bidirectional and has the same number of wavelengths. We fix the number of wavelengths to 12 wavelengths per fiber link. A larger number of wavelengths will have no impact on the presented results since it will increase the capacity of the OBS core network. Each OBS node can receive and route traffic. That means that each node in the OBS core network plays the roles of both edge node and core node at the same time. Moreover, unless stated otherwise, we fix burst assembly parameters as follows: (a) Maximum Assembly Time (MAT) to 0.1 s; (b) Maximum Burst Size (MBS) to 10000 KB. Also, we use Last Available Unused Channel with Void Filling (LAUC-VF) [16] algorithm for wavelength assignment in OBS edge nodes.

Fig. 9 shows the mean end-to-end delay for OBWMA using the analytical model and simulations. The results demonstrate clearly that the proposed model is quite accurate. In fact, while the mean end-to-end delay (over all of the loads) using the analytical model is 0.077, the mean end-to-end delay using simulations is 0.083; the standard deviation (over all of the loads) between the two is less than 2%. Moreover, Fig. 9 shows delay curves for WMN part and OBS part to show the contribution of each one of them to the overall end-to-end delay in OBWMA. We observe that OBS has the highest contribution to the end-to-end delay, especially, at very low loads. This is explained by the fact that burst assembly takes more time at low loads which affects the overall end-to-end delay.

Fig. 10 shows the end-to-end delay when varying MAT from 0.1 to 0.3 s. The results show that the end-to-end delay decreases whenever the MAT decreases.

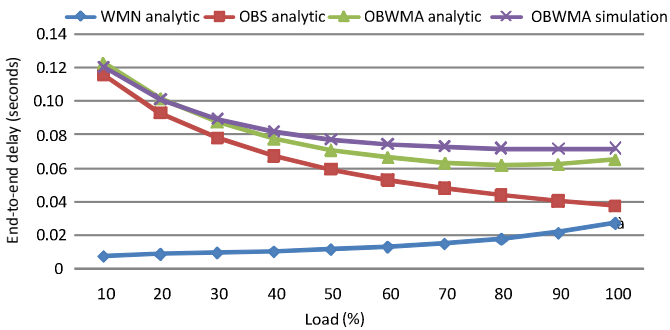

Fig. 9. End-to-End delay: analytic vs. simulations

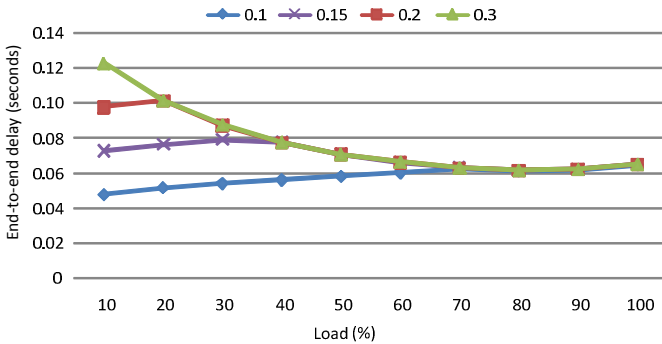

Fig. 10. Impact of maximum burst assembly time (seconds) on end-to-end delay

Fig. 11 shows the impact of varying WMN packet size on the delay. We consider values 500, 1000 and 1500 KB. We observe that the more the packet size increases, the more the delay decreases. This can be explained by the fact that at the same traffic load, when packet size is bigger, the number of packets in the WMN part is reduced and collisions are less likely to occur. Hence, the number of retransmissions due to collisions and, consequently, the delay are reduced.

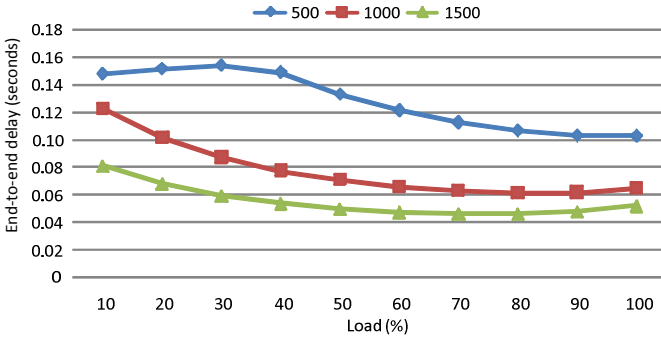

Fig. 11. Impact of WMN packet size (KB) on end-to-end delay

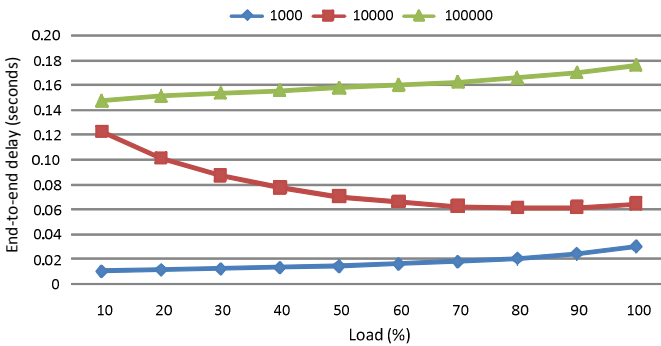

Fig. 12. End-to-End delay when varying Burst size (KB)

Fig. 12 shows end-to-end delay when varying maximum burst size in the OBS part of OBWMA. We set the maximum burst time to a large value (e.g., 10 s) to measure the real impact of burst size on end-to-end delay. We consider values: 1000, 10000 and 100000 KB. As expected, the more the burst size is larger, the more the delay is bigger. However, differently from the other values, when burst size is 10000 KB, delay tends to decrease when the load increases. We can say that at this value of burst size, delay is sensitive to the traffic intensity since the ratio [WMN packet size / OBS burst size] is moderate in this case. Indeed, with burst size 10000 KB, the ratio is roughly 1/10 (recall that default WMN packet size is 1000 KB in our simulations). For the other burst size values, the ratio is 1/1 and 1/100 for burst size 1000 KB and 100000 KB, respectively.

7 Conclusion

In this paper, we proposed a novel MAN architecture, called Optical Burst Wireless Mesh Architecture (OBWMA). OBWMA uses a set of wireless mesh networks for the access and an optical burst switching network as a backbone core network. To guarantee QoS in OBWMA, we developed an analytical model to compute end-to-end

delay and we proposed a novel adaptive burst assembly scheme (AHBA) for OBWMA. Also, we proposed a Control Bridge (CB) that coordinates QoS mapping at the border between WMN and OBS parts of OBWMA. Simulation results using ns-2 simulator showed the feasibility of OBWMA architecture, the accuracy of the proposed delay analytical model and the relevance of the proposed burst assembly scheme (AHBA).

In future work, we plan to consider bandwidth provisioning in the WMN and the OBS parts of OBWMA.

References

1. Chi, Y., Zhengbin, L., Anshi, X.: Dual-Fiber-Link OBS for Metropolitan Area Networks: Modelling, Analysis and Performance Evaluation. In: Proceedings of IEEE Globecom 2008 (2008)
2. Akyildiz, F., Wang, X., Wang, W.: Wireless Mesh Networks: A Survey. *Journal of Computer Networks* 47(4), 445–487 (2005)
3. Qiao, C., Yoo, M.: Optical burst switching (OBS) - a new paradigm for an optical Internet. *Journal of High Speed Networks* 8(1), 69–84 (1999)
4. Trigila, S., Lucidi, F., Raatikainen, K.: A service architecture for fixed and mobile convergence. *Computer Communications* 25(2), 133–148 (2002)
5. Luo, Y., Wang, T., Weinstein, S., Cvijetic, M., Nakamura, S.: Integrating Optical and Wireless Services in the Access Network. In: Proceedings of OFC 2006 (2006)
6. Luo, Y., Ansari, N., Wang, T., Cvijetic, M., Nakamura, S.: A QoS Architecture of integrating GEPON and WiMAX in the access network. In: Proceedings of IEEE Samoff Symposium 2006 (2006)
7. Wang, T., Junqiang, H., Suemura, Y., Nakamura, S.: Optical Wireless Integration at Network Edge. In: Proceedings of COIN-NGNCON 2006 (2006)
8. AlSabbagh, H.M., Chen, J., Qian, W.: A Simple Paradigm for Supporting the New Generation of Internet Based on WLAN over OBS. In: Proceeding of ICWMC 2007 (2007)
9. Martinez-Yelmo, I., Soto, I., Larrabeiti, D., Guerrero, C.: A Simulation-Based Study of TCP Performance over an Optical Burst Switched Backbone with 802.11 Access. In: Pras, A., van Sinderen, M. (eds.) EUNICE 2007. LNCS, vol. 4606, pp. 120–127. Springer, Heidelberg (2007)
10. Rezgui, J., Hafid, A., Gendreau, M.: A distributed admission control scheme for Wireless Mesh Networks. In: Proceedings of BROADNETS 2008 (2008)
11. Perkins, C., Bhagwat, P.: Highly dynamic destination sequenced distance-vector routing (DSDV) for mobile computers. In: Proceedings of ACM SIGCOMM 1994 (1994)
12. Cao, X., Li, J., Chen, Y., Qiao, C.: Assembling TCP/IP Packets in Optical Burst Switched Networks. In: Proceedings of IEEE Globecom 2002 (2002)
13. Belbekkouche, A., Hafid, M., Gendreau, M.: A Reinforcement Learning-Based Deflection Routing Scheme for Buffer-Less OBS Networks. In: Proceedings of IEEE Globecom 2008 (2008)
14. Vokkarane, M.K., Haridoss, K., Jue, J.P.: Threshold-based burst assembly policies for QoS support in optical burst-switched networks. In: Proceedings of SPIE OptiComm 2002 (2002)
15. NS-2 simulator, <http://www.isi.edu/nsnam/ns>
16. Yijun, X., Vandenhouste, M., Cankaya, H.C.: Control architecture in optical burst-switched WDM networks. *Journal on Selected Areas in Communications* 18(10), 1838–1851 (2000)