

# Distribution of SDTV and HDTV Using VLC Techniques for Domestic Applications

Timothy J. Amsdon, Martin J.N. Sibley<sup>(✉)</sup>, and Peter J. Mather

School of Computing and Engineering, The University of Huddersfield, Queensgate,  
Huddersfield HD1 3DH, UK  
{timothy.amsdon,m.j.n.sibley,p.j.mather}@hud.ac.uk

**Abstract.** This paper presents a visible light communication system that enables flat-panel TVs to receive DVB terrestrial, cable and satellite digital content wirelessly. The benefits of VLC over Wi-Fi and power-line networking based solutions are discussed, and the physical requirements of the system are defined. The paper also discusses how the MPEG transport stream of a set-top-box can be re-encoded for transmission over a free-space optical channel using a novel PPM modulation scheme.

**Keywords:** DVB-T · DVB-T2 · Digital TV · H.264 LED · MPEG · Offset PPM · VLC

## 1 Introduction

The International Telecommunication Union (ITU) reported in 2013 that there were over 1.4 billion households worldwide with at least one TV set, and that this represented 79% of the total worldwide households [1]. The ITU also reported that approximately 55% of these TV households are capable of receiving digital transmissions, meaning that at least 770 million TV sets are capable of receiving digital transmissions.

The deployment of consumer digital TV sets and digital broadcast services to support them is increasing. TV technology has evolved significantly over the last 20 years, and in particular, there has been a shift away from TV sets fitted with cathode-ray tube (CRT) technologies, to flat-panel, plasma, liquid crystal display (LCD), and more recently, OLED based technologies. These technologies have brought about significant reductions in power consumption, weight, bulk and the cost of TV sets, whilst increasing the reliability and the range of display screen sizes available. Flat-panel technologies have also facilitated the trend in wall-mounted sets, which has enabled consumers to reclaim floor space and enhance their viewing experience. However, in consumer premises, where solid wall construction techniques are used, routing of the signal and power cables to the rear panel of the set is problematic. In such cases, conduit or chasing is necessary to route the cables, which is potentially disruptive and expensive.

The rear panel of a modern, high-end TV sets has numerous connector interfaces, ranging from legacy analogue baseband video and audio inputs, to state-of-the-art digital HDMI interfaces. There are also RF connector inputs that feed broadcast content from terrestrial, cable and satellite services to an internal tuner/demodulator sub-system, the

type and specification of which is defined by the region of the world the set operates. Furthermore, modern sets now provide access to digital content via USB, Ethernet, Wi-Fi and, in some cases, power-line networking. The inclusion of TCP/IP enables consumers to access online services such as video streaming and web-browsing.

Given modern TV sets have access to digital broadcasting and internet services, and that the support for legacy analogue baseband devices such as VCRs is declining, TV manufacturers have the opportunity to eliminate all of the connector interfaces, including the RF connectors, from the rear panel of the set and use completely all-digital, wireless based connectivity. This leads to a number of desirable benefits. Firstly, this approach benefits the consumer by simplifying wall-mount installation. Secondly, and most obviously, it reduces the cost of the TV set. Not only does the elimination of the connectors reduce cost, so too does the elimination of their associated internal support circuitry and PCB area. In addition, any software overhead associated with this circuitry is also eliminated. In particular, the elimination of the RF connectors is significant, since it leads to the removal of the tuner/demodulator sub-system that enables reception of broadcast services. As already stated, this sub-system is defined by the reception type and region of the world the set operates. By removing it and sourcing the content by alternate means, the set effectively becomes a region-less monitor, enabling TV manufacturers to produce generic TV sets that operate in any region of the world.

This paper presents a visible light communication (VLC) based system to address this opportunity, presenting the case for VLC over Wi-Fi and power-line networking based solutions. The physical requirements of the system are defined, and a novel modulation scheme for the system is also presented. The paper is primarily focused on the distribution of digital based terrestrial, cable and satellite broadcasting services wirelessly to a consumer TV set in a domestic setting.

## 2 DVB Standards

Digital broadcasting standards and the function of the tuner/demodulator is easily explained using the all-digital DVB broadcasting model used in Western Europe [2]. The standards applicable to terrestrial, cable and satellite services are shown in Table 1. The modulation schemes employed by each of the broadcast standards are very different, with each chosen to achieve optimal data transmission over channels with specific characteristics and impairments. However, all three DVB modulation schemes are encoded with the same underlying digital transport stream, namely the MPEG transport stream (MPEG TS). MPEG is a digital compression codec that is used to compress video and audio to facilitate transmission across band-limited channels. The key compression standards applicable to DVB are MPEG-2 for standard-definition TV (SDTV) and H.264 for high-definition TV (HDTV). DVB standards with suffix '2' e.g. DVB-T2, are capable of receiving SDTV and HDTV, and standards without the suffix e.g. DVB-T are only capable of receiving SDTV.

**Table 1.** DVB standards: terrestrial, cable and satellite broadcasts

Broadcast type	Standard	Bit-rate (Mbit/s)	Modulation and conditions
Terrestrial	DVB-T	31.7	COFDM: Constellation 64-QAM, code rate 7/8, guard interval 1/32, 8 K FFT, BW 8 MHz
	DVB-T2	50.2	COFDM: Constellation 256-QAM, code rate 5/6, guard interval 1/128, 32 K FFT, BW 8 MHz
Cable	DVB-C	51.3	Constellation 256-QAM, BW 8 MHz
	DVB-C2	83.1	Constellation 4096-QAM, BW 8 MHz
Satellite	DVB-S	42.9	Constellation QPSK, BW 36 MHz
	DVB-S2	64.5	Constellation 8PSK, BW 36 MHz

A simplified block diagram of each DVB standards transmit and receive path is shown in Fig. 1. The basic principle of operation begins at the transmitter where video and audio are compressed by the MPEG encoder. The subsequent multiplexer interleaves multiple video, audio and data streams into a single MPEG TS. This is done by assigning programme identification (PID) sequences to the content so the receiver can reconstruct the original independent streams (demultiplexing). Scrambling (encrypting) data streams is also possible to restrict access to subscriber based services. The resultant MPEG TS is then presented at the specific modulator i.e. QPSK, QAM, COFDM, for optimal transmission over a specific channel [3].

At the TV receiver, the process of the transmitter is reversed. The desired transmission channel is first selected and isolated from other channels by the tuner. The selected channel is then presented to the demodulator where appropriate demodulation techniques recover the MPEG TS. The transport stream is then demultiplexed using PIDs, and descrambled as necessary, to recover the independent MPEG video and audio streams. The required video and audio streams are then decoded by the MPEG decoder so that the original video and audio is reproduced.

By removing the tuner/demodulator function from the TV set, and integrating it into a wireless transmitter, the most convenient place to access the digital broadcast content is at the MPEG TS interface, since the stream is highly compressed and potentially encrypted. The transport stream is available at the output of the DVB demodulator, and is configurable for either serial or parallel output mode. The former mode is preferable for transmission over a wireless channel, and is composed of a four key lines. The first is the transport streams 50% duty cycle reference clock. The second is the serial data line, which transports payloads of 188 bytes ( $188 \times 8 = 1504$  bits). The third is the valid line which indicates the beginning and ending of each payload, this line remains high

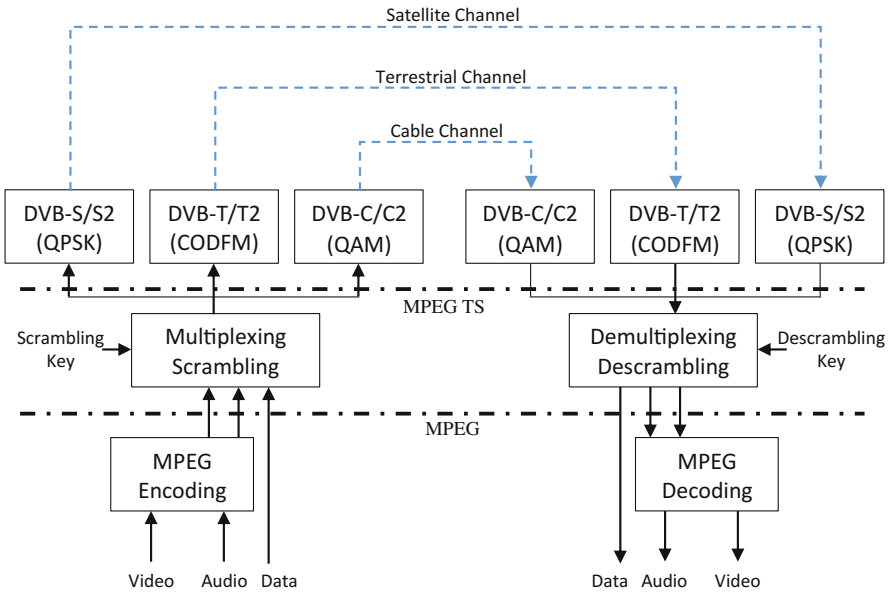

**Fig. 1.** DVB standards: terrestrial, cable and satellite transmit and receive paths

during the transmission of payload bytes d0 to d187. The fourth is the synchronisation line, which remains high only for the duration of d0 byte, or the first bit of the payload [4].

These lines can be combined into a single data stream using digital processing techniques and then re-encoded for transmission over a wireless channel to a TV set. The receiving TV set then only needs to decode the transmitted signal and use an MPEG decoder to reproduce the audio and video.

### 3 Wi-Fi and Power-Line

The superficially obvious candidate for transmitting the MPEG TS is Wi-Fi, but given that the demand placed on Wi-Fi is growing, bandwidth capacity is becoming an issue. Wi-Fi transmissions also suffer from an inherent security weakness caused by the fact that RF signals can penetrate the walls of buildings and therefore can be broadcast beyond the consumer premises. Indoor coverage ranges for Wi-Fi standards 802.11b and 802.11g are typically 50 m, and 802.11n around 100 m, meaning that transmissions can be intercepted and the content accessed by eavesdroppers. Power-line networking, although not a wireless based system, is also an attractive candidate as it provides dual purposing of the power cable to the set. This scheme enables both mains power and data transmission to coexist on the same cable, and is achieved by superimposing a digitally modulated OFDM signal onto the mains supply voltage. However, domestic power distribution systems are not designed to support data transmission, and this system is limited by multipath dispersion and the impulsive noise [5]. Wi-Fi and power-line

systems are also required to meet stringent regulatory compliance due to both systems radiating RF energy which can interfere with other electrical devices.

## 4 VLC

A visible light based solution is compelling as it overcomes some of the problems encountered with Wi-Fi. Firstly, VLC uses a region of the electromagnetic (EM) spectrum which is unlicensed and unregulated (375 nm and 780 nm) [6]. This eliminates the regulatory compliance required by Wi-Fi and powerline solutions. Secondly, visible light has inherent security, since it cannot penetrate walls, ceilings and floors. Thirdly, VLC is immune to electrical interference, and therefore transmissions are not impaired by electrical noise or spurious signals. Finally, the alignment of a VLC transmitter and receiver is intuitive, given that the light in this range is visible, the emission can be positioned and focused onto the receiver's photodetector (PD) to achieve maximum signal to noise performance.

The first free-space optical wireless system was demonstrated in 1979 by Gfeller and Bapst [7], and operated in the near-IR (950 nm) range. The system achieved a bit-rate of 1Mbit/s using diffuse transmission and On-off keying (OOK) modulation to communicate with a cluster of computer terminals. However, it was not until 2003 that Tanaka et al. demonstrated a visible white-light LED based dual purpose illumination and communication system. This also used diffuse transmission and OOK modulation, achieving a bit-rate of 400 Mbit/s [8].

Diffuse transmission relies on the reflections from walls, ceiling, floor and other surfaces to increase the coverage area of the radiating source. Diffuse transmission is desirable for mobile applications, but results in significant multipath, and inter-symbol interference (ISI). In order to overcome this, robust modulation schemes such as direct-current-biased optical OFDM (DCO-OFDM) [9] and discrete multitone (DMT) [10] have been developed. These schemes reportedly achieve gigabits/s rates, but have complicated architectures compared to OOK and PPM schemes.

Research has demonstrated that bit-rates are limited by the power output and the bandwidth of the LED. Typical LED bandwidth is in excess of 10 MHz, but is extendable using electrical equalisation and optical filtering. Li et al. presented a system using combination of blue optical filtering, and passive and active equalisation at the receiver (post-equalisation) to achieve bandwidths in excess of 150 MHz, and enabling bit-rates of 340 Mbit/s using OOK [11]. The blue optical filtering is used to increase the bandwidth of LEDs by removing the slower yellow component introduced by LEDs that use yellow phosphor.

### 4.1 Directed LOS Transmission

As described, most VLC research is focused on the diffuse transmission model because it provides the widest coverage area. However, due to multipath, robust modulation schemes and complex system architectures are required. The transmission model proposed here is the directed LOS channel model, since this model assumes that there

are no reflections from walls, ceiling, floor and other surfaces present at the receiver's PD, enabling a simpler OOK and PPM schemes to be used. The transmitter and receiver in this case are also assumed to be static.

The directed LOS transmission function is defined by Eq. 1.

$$H(\varnothing)_{LOS} = \begin{cases} \frac{A_{R_s}}{d^2} Ro(\varnothing) \cos(\psi) & \text{for } 0 \leq \psi \leq \psi_c \\ 0 & \text{for } \psi > \psi_c \end{cases} \quad (1)$$

Where  $A_{R_s}$  is defined as the PD area,  $d$  is the distance between the LED and the PD,  $\psi$  is the angle of incidence, and  $\psi_c$  is the field of view (FOV) of the PD.  $Ro(\varnothing)$  is the radiant intensity of the LED which is assumed to be Lambertian [12] as shown in Eq. 2.

$$Ro(\varnothing) = \left[ \frac{m + 1}{2\pi} \right] \cos^m(\varnothing) \quad (2)$$

Where  $m$  is the order of the Lambertian emission, and is related to the semi-angle (half power)  $\varnothing_{1/2}$  of the LED emission. Equation 3 defines  $m$ .

$$m = -\frac{\ln 2}{\ln(\cos(\varnothing_{1/2}))} \quad (3)$$

### 4.2 Channel Model

Figure 2 shows the basic block diagram of the transmitter and receiver elements of an optical communications system. At the transmitter a transconductance amplifier (TCA) converts the voltage levels of data stream into current changes that intensity modulates the LED. At the receiver, the PD detects these intensity changes and converts them back to current changes. A transimpedance amplifier (TIA) then converts the current back into voltage changes.

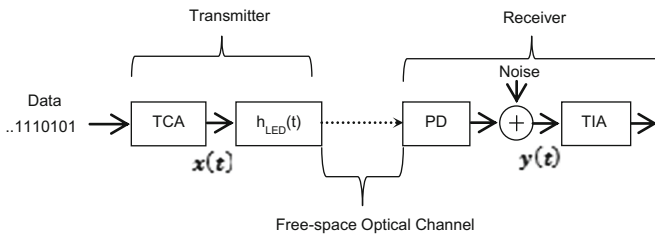

Fig. 2. Optical communications transmitter and receiver elements

The received signal  $y(t)$  is a distorted and noisy representation of the intensity modulating signal  $x(t)$ . The transfer function [13] of the system is given by Eq. 4.

$$y(t) = R \cdot P_{LED} \cdot H(\varnothing)_{LOS} \cdot [x(t) \otimes h(t)] + n(t) \tag{4}$$

R is the responsivity of the receiving PD,  $P_{LED}$  is the average output power of the LED, and  $H(\varnothing)_{LOS}$  is the directed LOS transmission function. The symbol  $\otimes$  denotes convolution, where  $x(t)$  is the intensity modulating signal that is convolved with the optical impulse response  $h(t)$  of the channel (Gaussian). Additive noise is represented by  $n(t)$ , and is the root mean square noise current introduced by the receiver.

### 4.3 Physical Requirements

Based on the directed LOS model, the physical requirements of the VLC system can be defined. A set-top-box (STB) capable of receiving DVB broadcasts and providing the necessary MPEG TS can be integrated with the VLC transmitter. This integrated VLC STB is then located in the plenum space above the room containing the TV set. The transmitting LED is mounted on a gimbal suspended from the ceiling, and providing 360° rotation. The wireless TV is now mountable on any wall in the room, and only the power cable needs consideration. A lens mounted on the LED, can then be used to provide focusing of the transmitted light onto TVs PD. Installation of the VLC STB in the plenum space is less disruptive, as power and RF feed cables for terrestrial, cable and satellite services are more readily accessible in this location. Figure 3 shows the physical interpretation of the system. Programme selection is possible through the TV using IR remote control. The TV is also be fitted with an IR transmitter to facilitate communication with the VLC STB.

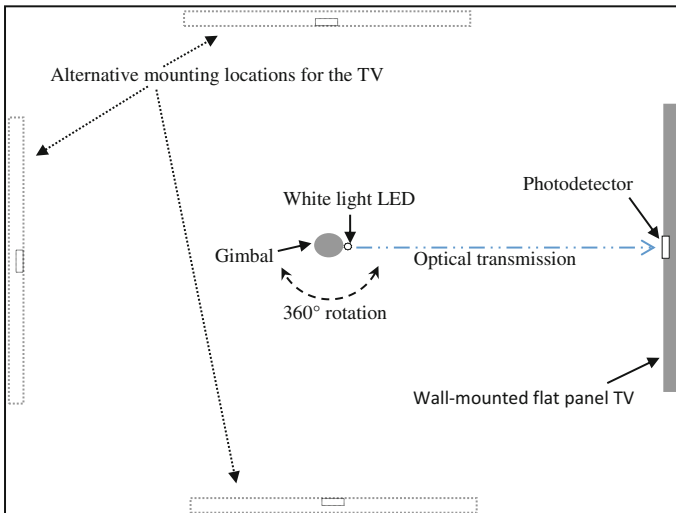

Fig. 3. Optical communications transmitter and receiver elements

### 5 Inversion Offset PPM Scheme

A novel PPM scheme, inverse offset PPM (IOPPM), is proposed for the system. This scheme is to be used to re-encode the serial MPEG TS, provided by a DVB STB, and then use the modified data stream to intensity modulating the LED.

As described earlier, the primary limiting factors of a VLC system are the output power and the bandwidth of the LED. Based on the DVB standards for terrestrial, cable and satellite broadcasts, the highest bit-rate is generated by the DVB-2 standard which is 83.1 Mbits/s (shown in Table 1). This is inside the bandwidth of 150 MHz achieved with electrical equalization and optical filtering. Also, the optical signal power at the PD is increased by using directed LOS transmission and lens focusing at the LED. However, the modulation scheme should maximise sensitivity and minimise bandwidth.

**Table 2.** 3-bit coding table: digital PPM, OPPM and IOPPM

PCM word	Digital PPM codeword	OPPM codeword	IOPPM codeword <i>IOPPM<sup>+</sup></i> <i>IOPPM<sup>-</sup></i>
000	0000 0001	0 000	100 <sup>+</sup> 001 <sup>-</sup>
001	0000 0010	0 001	001 <sup>+</sup> 000 <sup>-</sup>
010	0000 0100	0 010	010 <sup>+</sup> 000 <sup>-</sup>
011	0000 1000	0 100	100 <sup>+</sup> 000 <sup>-</sup>
100	0001 0000	1 000	001 <sup>+</sup> 100 <sup>-</sup>
101	0010 0000	1 001	000 <sup>+</sup> 001 <sup>-</sup>
110	0100 0000	1 010	000 <sup>+</sup> 010 <sup>-</sup>
111	1000 0000	1 100	000 <sup>+</sup> 100 <sup>-</sup>

IOPMM is a tertiary coding scheme based on offset PPM (OPPM), originally developed by Sibley [14]. OPPM was found to have similar performance to digital PPM, but at half the line rate and 3.1 dB higher sensitivity. Table 2 shows the coding of a 3-bit PCM word for digital PPM, OPPM and IOPPM. OPPM achieves the line rate reduction by introducing a sign bit to the received PCM word (denoted in *italic*). However, the bandwidth of the transmitted codeword is higher than the PCM word due to the addition of an extra slot time to accommodate the sign bit. IOPPM uses two signal paths, *IOPPM<sup>+</sup>* and *IOPPM<sup>-</sup>* to



convey the sign bit. This enables the bandwidth of the IOPPM codeword to equal that of the PCM word, but has the consequence of reducing sensitivity by 3 dB.

Figure 4 demonstrates how the  $IOPPM^+$  and  $IOPPM^-$  codeword paths are used to intensity modulate the LED. The LED is biased at a mid-point radiant intensity set by  $R_1$ ,  $R_2$  and  $Q_1$ . If  $IOPPM^+$  is at logic '0', as shown,  $Q_2$  is off and no increase in  $Q_1$  base bias occurs. However, if  $IOPPM^-$  is at logic '1'  $Q_3$  is forward biased and  $Q_1$  base bias is reduced, resulting in a decrease in the radiant intensity of the LED. This push-pull based driver approach divides the LED radiant intensity in two, thereby enabling the transmission of the  $IOPPM^+$  and  $IOPPM^-$  streams.

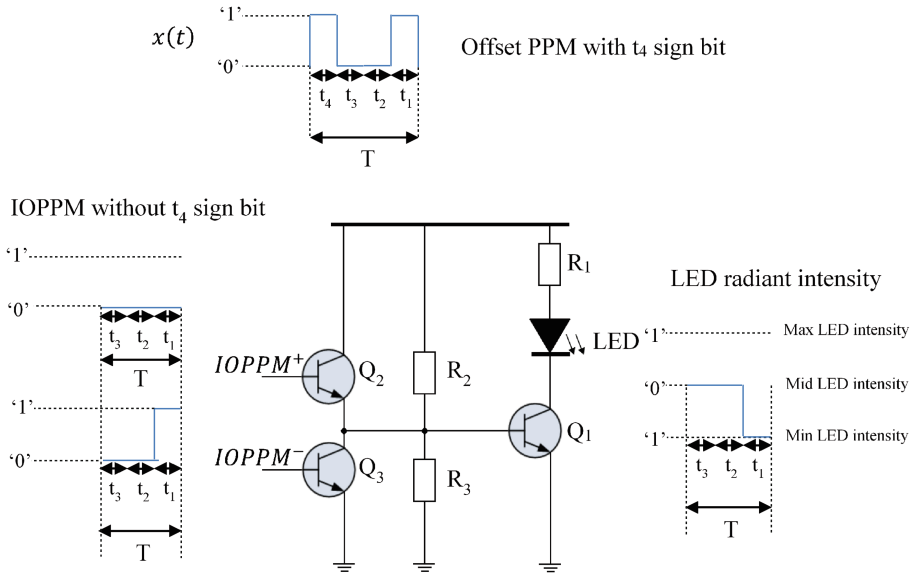

Fig. 4. Optical communications transmitter and receiver elements

## 6 Results

Most of the work underway on this research investigation is of a practical nature. Thus far a DVB-T/T2 tuner/demodulator reference design from Silicon Labs has been used and configured to generate a serial MPEG TS output. Off-air testing has revealed that the HDTV multiplex for C41 (634 MHz) from Emley Moor transmitter (Kirklees, England) is operating at a bit rate of 40.21 Mbits/s, and this stream is currently being used to develop an FPGA implementation of the IOPPM encoder and decoder. A DVB-T2 STB has also been successfully reverse engineered in order to access its MPEG decoder. Successful testing of the MPEG TS interface between the Silicon Labs reference board and STB MPEG decoder has been carried out. Design work is also underway on the LED drive circuitry using HEXFET devices.

## 7 Conclusions

A VLC system for wireless connectivity to flat-panel TVs using LOS transmission has been presented. LOS transmission was chosen as it eliminates multipath, thereby reducing ISI. The concept of a VLC STB has been presented, where DVB broadcast content for terrestrial, cable and satellite can be accessed at the MPEG TS interface and the re-encoded using a novel coding scheme (IOPPM), and then used to intensity modulate an LED. The IOPPM scheme has been shown to have a line rate equal to input word when 3-bit encoding is used, but incurs a 3 dB loss in sensitivity as a result. It has also been indicated that LED bandwidth can be extended from 10 MHz to 150 MHz using a combination of post-equalisation and blue optical filtering.

## References

1. ITU: International Telecommunications Union (ITU) Measuring Information Society, Geneva, Switzerland (2013)
2. DVB Project Office: 2nd Generation Terrestrial: The World's Most Advanced Digital Terrestrial TV System. DVB Project Office ([dvb@dvb.org](mailto:dvb@dvb.org)) (2015)
3. ETSI: ETSI EN 300 429 v1.2.1. EN 300 429 V1.2.1 (1998-04); European Standard (Telecommunications series); Digital Video Broadcasting (DVB); Framing structure, channel coding and modulation for cable systems. ETSI, Valbonne (2004)
4. ETSI: ETSI EN 300 744 V1.6.1. ETSI EN 300 744 V1.6.1 (2009-01); European Standard (Telecommunications series); Digital Video Broadcasting (DVB); Framing structure, channel coding and modulation for digital terrestrial television. ETSI, Cedex (2009). [http://www.nordig.org/pdf/NorDig-Unified\\_ver\\_2.4.pdf](http://www.nordig.org/pdf/NorDig-Unified_ver_2.4.pdf)
5. Zhang, H., Yang, L., Hanzo, L.: IET communications: performance analysis of orthogonal frequency division multiplexing systems in dispersive indoor power line channels inflicting asynchronous impulsive noise institution of engineering and technology (2016). doi:[10.1049/iet-com.2015.0702](https://doi.org/10.1049/iet-com.2015.0702)
6. Lee, C.: Advanced trends in wireless communications, pp. 327–338 (2011)
7. Gfeller, F.R.: Wireless in-house data communication via diffuse infrared radiation. *Proc. IEEE* **67**, 1474–1486 (1979)
8. Tanaka, Y.K.: Indoor visible light data transmission system utilizing white LED lights. *IEICE Trans. Commun.* **E86-B**, 2440–2454 (2003)
9. Afgani, M.H.: Visible light communication using OFDM. In: Proceedings of the 2nd International Conference Testbeds and Research Infrastructures for the Development of Networks and Communities (TRIDENTCOM), pp. 129–134 (2006)
10. Vucic, J.K.: 513 Mbit/s visible light communications link based on DMT-modulation of a white LED. *J. Lightwave Technol.* **28**, 3512–3518 (2010)
11. Li, H.C.: High bandwidth visible light communications based on a post-equalization circuit. *IEEE Photonics Technol. Lett.* **26**, 119–122 (2014)
12. Haigh, P.A.: Transmitter Distribution for MIMO Visible Light Communication Systems. PGNet (2011)
13. Ghassemlooy, Z.: Indoor Optical Wireless Communication Systems – Part I: Review (2003)
14. Sibley, M.: Analysis of offset pulse position modulation - a novel reduced bandwidth coding scheme. *IET Optoelectron.* **5**, 144–150 (2010)