



Home Energy Monitoring System Towards Smart Control of Energy Consumption

Zakariae Jebroni¹(✉), Jose A. Afonso², and Belkassem Tidhaf¹

¹ Laboratory of Embedded Electronics Systems and Renewable Energy (SEEER), University Mohammed Premier, Oujda, Morocco
zakariae.jebroni@gmail.com

² CMEMS-Uminho Center, University of Minho, Guimarães, Portugal

Abstract. The need to manage, control and reduce energy consumption has led researchers to propose reliable solutions based on new technologies to achieve this goal. Our contribution in this subject is presented in this paper and consists of the design, implementation and testing of a home energy monitoring system. The presented system is dedicated for residential customers and allows the monitoring and control of the energy consumption, based on distributed and central processing. The system includes distributed monitoring devices, a gateway and a graphical user interface (GUI). To connect the all parts we use a hybrid wireless solution based on the Wi-Fi and Bluetooth Low Energy standards. We present the design and the implementation of the monitoring device hardware as well as the embedded software used to calculate the electrical quantities. We also present the calibration methodology used to eliminate gain and offset errors. In terms of performance test results, we have achieved voltage measurement accuracy below 0.2% and current measurement accuracy below 0.5%. A GUI was also developed for the user to visualize and control remotely the household appliances.

Keywords: Energy monitoring system · Home energy management system · Smart home · Smart metering

1 Introduction

The growing demand for electrical energy by customers has created new challenges in the management and control area. In the past, as the energy consumption was moderate, only basic equipment was needed to manage the electricity grid. Therefore, on the one hand, the electricity operators used basic measurement systems to control the energy consumption and, on the other hand, the customers did not pay attention to the control of the consumption. As the number of customers increased and the electricity grid became complicated, it was necessary to propose new solutions based on new technologies to better manage the electrical energy production-consumption chain [1].

Currently, the research in this area focuses on the management and control of electrical energy. Electricity operators are switching from static systems to Advanced Metering Infrastructures (AMI). This intelligent and real-time management is dedicated for energy theft detection, CO₂ emissions reduction, remote control and command of the electrical grid and to save energy production as much as possible [2]. The management

of electrical energy on the production side was not enough to reduce its production. The population growth, urbanization as well as irrational use of electrical energy increase its consumption [3]. Therefore, to reduce the energy consumption and to shave the power demand, rational consumption on the demand side must be ensured by reducing energy consumption and eliminating peak power demand through the time shifting of the load. By managing and controlling energy consumption in demand side, satisfactory results may be achieved. Firstly, by reducing consumption on the consumer side, the bill will be reduced. Secondly, real-time management and forecasting through intelligent management systems in the production side will provide electricity operators a solid basis for balancing the production-to-consumption ratio over long term and, therefore, managing energy sources efficiently. Finally, on the environmental side, by reducing the energy consumption and losses, the CO₂ emissions will be reduced.

In order to manage and control energy consumption, it is necessary to introduce a reliable embedded system that can be integrated into the AMI, either directly or indirectly. That means, in the first case, the development of a Smart Home Energy Management System (SHEMS) connected to the Smart Grid Management System (SGMS), which is integrated directly into the AMI. The alternative is the development of this system but keeping it connectionless to the SGMS. In this case, the role of the system remains the same (reducing energy consumption and shaving power demand), but we keep independence between the customer and the electricity operator.

The embedded system contains two important parts: The monitoring system and the intelligent algorithm that manage the energy consumption. The monitoring system is the basis of the SHEMS [4] and consists mainly of several distributed wireless sensor devices, or Monitoring Devices (MDs), as well as a Graphical User Interface (GUI). A MD has the role of measuring the energy consumption of a household appliance, and then transmitting the measurement data to a local central device. In order to transmit the data, we may use a single wireless communication technology, such as Wi-Fi [5], Bluetooth, ZigBee [6] or GSM [7], or hybrid method, like Bluetooth/Wi-Fi [8], in the case where a gateway is used. In a house, several MDs form a Home Area Network (HAN). Regarding the data processing and calculation of electrical quantities, local processing and distributed calculation are more efficient in term of communication overhead and time calculation [9]. The GUI is used to monitor and control the monitoring system, and, therefore, the household appliances.

As related works, there are some publications in this area. Ahsan et al. [9] discuss the advantages of the distributed processing for home energy management system compared to centralized system. Their application is dedicated for smart grid, so it depends mainly of the electricity operator. The proposed system is tested in a mobile phone (Android app), but they did not propose a monitoring device hardware. In [10] Nesimi Ertugrul et al. propose a home energy management system for demand-based tariff, where they attempt to reduce the peak demand of household, but the system can create some inconvenience to the user, because it acts on any appliance without taking in consideration if the user uses this later. For that, they propose in the future to add a user priorities system to improve the old one. They also present the hardware of test, but they did not give information about the measurement reliability. In [4] the authors present a bill forecasting application for energy management based on an energy monitoring system. The authors assume that the monitoring system should be a learning tool and the user should make less effort to dealing with the system. In the end,

they present an application of the monitoring system where they use Wi-Fi as the communication system. Afonso et al. [6] propose a monitoring system to monitor energy consumption and power quality. They presented the measurement accuracy of their designed monitoring device as well as the used GUI.

The aim of our contribution is to design and implement a SHEMS mainly adapted for use in the case of payment by consumption slices, like in Morocco. In this payment system, the price of one kWh is not related to the period of consumption (morning, afternoon or evening), but it is related to the amount of energy consumed, which means that when the monthly energy consumption increases, the price of energy increases. Table 1 shows the price per unit of electrical energy in Morocco.

Therefore, we propose a SHEMS that integrates an energy management algorithm. This, based on energy consumption, manages the operation of the household appliances. We distinguish between direct contact appliances with the user and indirect contact appliances, which was the issue of the proposition in [10]. For the first category, the system will not act on such this equipment, because maybe the user are using it. For example, if there is a visual interaction between the user and a television, the system will not turn off the appliance, it will just send notification for the customer in the case of an overuse. For the second category, the system can manage the appliances without notifying the user, like turning on/off a refrigerator, because there is no direct interaction between this later and the user. The proposed SHEMS is not totally connected to the electricity operator in order to keep some privacy for the customer.

In this paper, we present the first element of the whole system – the monitoring system. In the second section, we present the developed system, including the chosen communication technologies, the developed hardware, as well as the software of the monitoring device. In the third section, we present some experimental results of the measurement accuracy and the proper functioning of the measurement system. We present also, in the same section, the developed GUI dedicated to monitor and control the appliances. We finalize this paper with conclusions.

Table 1. Consumption slices per month and their price [11].

Consumption slices per month	kWh price in Moroccan dirham (MAD)
0 to 100 kWh	0.9010
101 to 150 kWh	1.0732
151 to 200 kWh	1.0732
201 to 300 kWh	1.1676
301 to 500 kWh	1.3817
>500kWh	1.5958

2 System Development

2.1 Overview of the Communication Network

The main objective of the monitoring system is to make possible the remote monitoring and the remote control of the household appliances. To achieve this goal, we must

implement a complete system consisting of embedded electronics and telecommunication module(s) working together. The proposed system consists of several connected parts. The connection between parts is guaranteed by one or more wireless technologies. As mentioned before, several wireless communication technologies exist in the market. For this system, a low cost, low energy consumption wireless technology for the wireless sensor nodes is required and, for a future implementation, we have to guarantee the access from outside the home. According to these requirements and based on studies done on [12, 13], which discussed the benefits of Bluetooth Low Energy (BLE) for that kind of applications, we opted to use a hybrid communication solution to connect the whole system. Figure 1 shows the architecture of the monitoring system communication network. The system is composed by several elements connected to each other by wireless networks. The Monitoring Devices (MD1 to MDn) are connected to the BLE/Wi-Fi gateway via a BLE connection. We use the PSoC 4 BLE module from Cypress as processing and communication unit. This module is characterized by a 32-bit ARM Cortex-M0 processor core and an integrated Bluetooth 4.2 protocol stack. It also integrates programmable analog front ends used for measurements and a real time clock (RTC) used for time requirements.

As shown on Fig. 1, a user can view the power consumption, manage and control devices through the gateway using a client device (computer or phone). The connection between the client devices and the gateway is guaranteed by a Wi-Fi network through the Wi-Fi Access Point (Wi-Fi AP).

The gateway used in this system is a Raspberry Pi 3. This component has two roles. The first one is to ensure the connection between all devices. The second role is to collect, compute and store measurement data and to transmit control commands. In this case, this component presents itself as a local central device for the client.

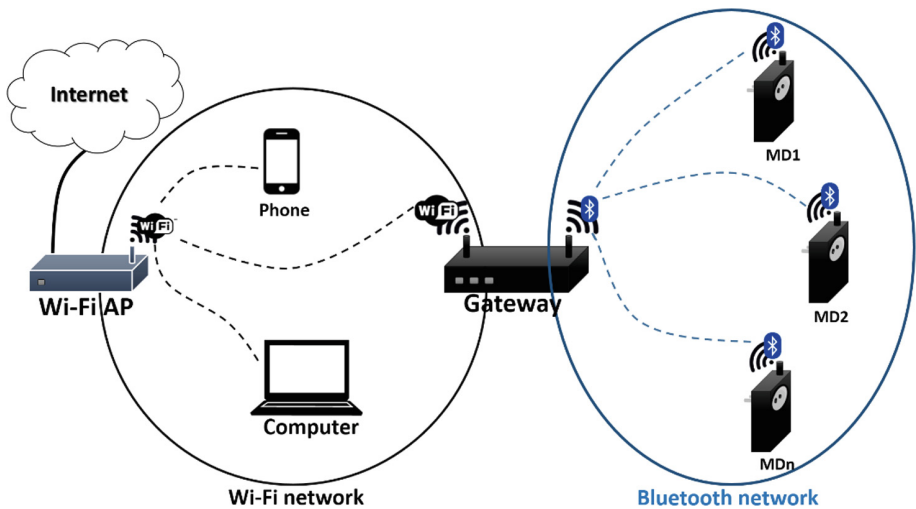

Fig. 1. Monitoring system communication network.

2.2 Developed Monitoring Device Hardware

The developed MD is shown in Figs. 2 and 3 presents its block diagram. It contains voltage and current sensors, signal conditioners and a processing and wireless communication unit. To calculate the power, and thus the energy consumption, we have to measure the instantaneous voltage and the instantaneous current. The MD was developed for a single-phase 230 V/50 Hz line.

Figure 4 presents the monitoring device board, whereas Fig. 5 presents its power supply board. Referring to Fig. 4, for the voltage chain we use as sensor a voltage divider based on resistors. The output-input ratio is 0.00057. The voltage sensor is following by the isolation amplifier AMC1100. This component ensure isolation between the grid and the application to secure the processing core from high voltage. The differential output voltage of the AMC1100 contains a negative part, but the Analog-to-Digital Converter (ADC) of the processing unit accepts only positive signals. For this reason, we added a signal conditioner based on operational amplifier TL082 (Fig. 6(a)) to add some offset and eliminate the negative part from the signal.

For the current chain, we use as sensor the TA12-100 current transformer. This component is characterized by a current ratio of 1000:1 and 1% accuracy. In its output, we placed a resistor to get a voltage proportional to the current. The resistor value (220 Ω) was chosen in such a way to have, for the maximum current, a maximum voltage equal to 1.5 V. To account for the negative part of the current, we added a fixed voltage as offset on one of output current sensor terminals as shown in Fig. 6(b).

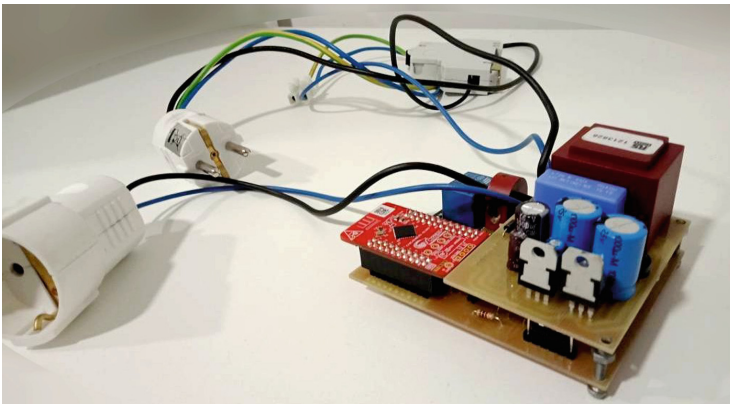

Fig. 2. Developed monitoring device prototype.

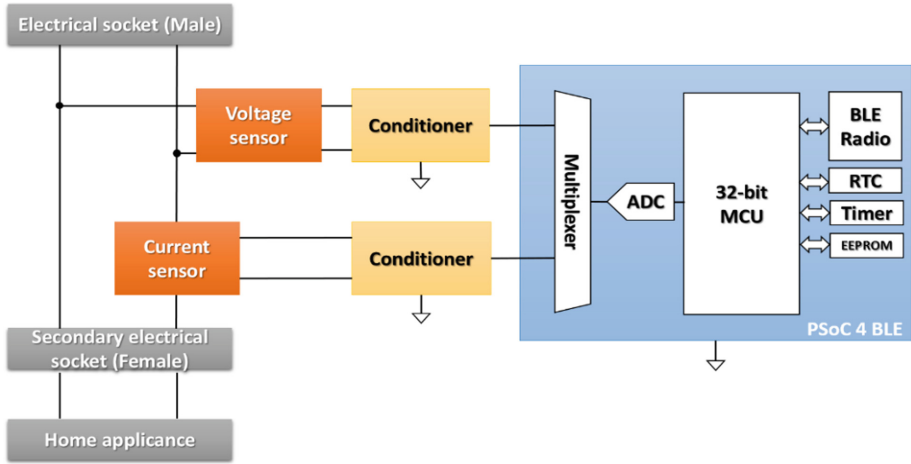

Fig. 3. Block diagram of the monitoring device.

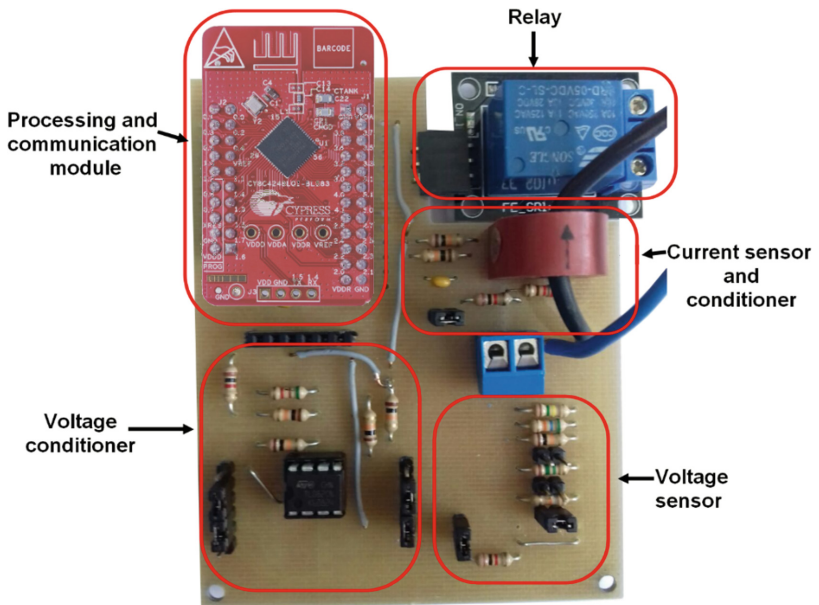

Fig. 4. Monitoring device circuit board.

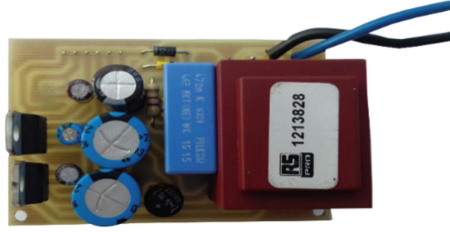

Fig. 5. Monitoring device power supply.

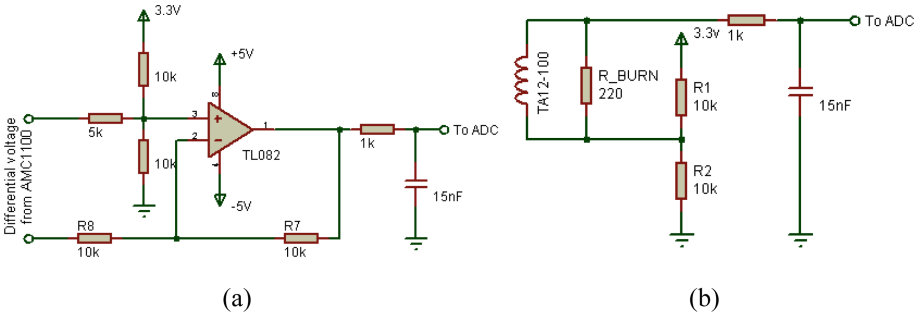

Fig. 6. (a) Voltage conditioner circuit and (b) current measurement and conditioner circuit.

In the developed monitoring device, we use the PSoC 4 BLE module as processing and communication unit. Therefore, after conditioning and filtering the signal from the two chains, we use the integrated ADC of the unit to convert the analog signal. The sampling frequency is 5000 samples per second. We note that the Shannon sampling criterion is widely respected. The electrical quantities computation is done in software inside the processing and communication unit, as explained in the next subsection.

2.3 Software Computation and System Calibration

As shown in Fig. 7, we use an interrupt mode in the ADC to detect an end of conversion. After the end of each conversion, we read the conversion register values for the voltage and the current. We use these values to calculate the instantaneous power in the ADC interrupt function. These three electrical quantities are calculated through Eqs. 1, 2 and 3, respectively.

$$V = G_v(k_v \cdot V_{REG} + V_{DCOFF})V_{REF} \tag{1}$$

where G_v is the voltage gain used to calibrate the voltage chain gain, k_v is a coefficient used to convert the value of the ADC register into a real value (equal to $\frac{1}{ADC \text{ resolution}}$), V_{REG} is the numerical value of the voltage stored into the corresponding register, V_{DCOFF} is the voltage offset used to calibrate the offset into the voltage chain, if exists. And V_{REF} is the voltage reference.

$$I = G_i(k_i \cdot I_{REG} + I_{DCOFF})I_{REF} \quad (2)$$

where each term is the same as the voltage equation, except that is used for the current chain.

$$P = V \cdot I \quad (3)$$

We add these values to temporary variables to calculate the RMS values and average values. After calculating and storing the new values, we raise a flag to notify that there is a new data.

In the infinite loop, we test if the new conversion flag is on. For each end conversion, we wait until reaching 5000 samples, which corresponds to a time interval of one second, and this represent the Low Rate Sampling Period (LRSP). When this condition is verified, we calculate the RMS values, active power, energy and others quantities with the equations presented in Table 2.

Table 2. Formulas used to calculate the RMS and average values.

Electrical quantity	Formula	Description
RMS voltage	$V_{RMS} = \sqrt{\frac{1}{N} \sum_{i=1}^N V_i^2}$	N is the number of samples in one period
RMS current	$I_{RMS} = \sqrt{\frac{1}{N} \sum_{i=1}^N I_i^2}$	N is the number of samples in one period
Average power	$P_{AVG} = \frac{1}{N} \sum_{i=1}^N P_i$	N is the number of samples in one period
Power factor	$PF = \frac{P_{AVG}}{V_{RMS} \cdot I_{RMS}}$	
Energy	$E_i = E_{i-1} + \frac{P_{AVG_i}}{N_s}$	E_i and E_{i-1} present the current energy value and the previous energy value. The term $\frac{P_{AVG_i}}{N_s}$ presents the energy consumed in the last LRSP, where $N_s = \frac{3600}{LRSP}$. In this case the energy unit is Wh

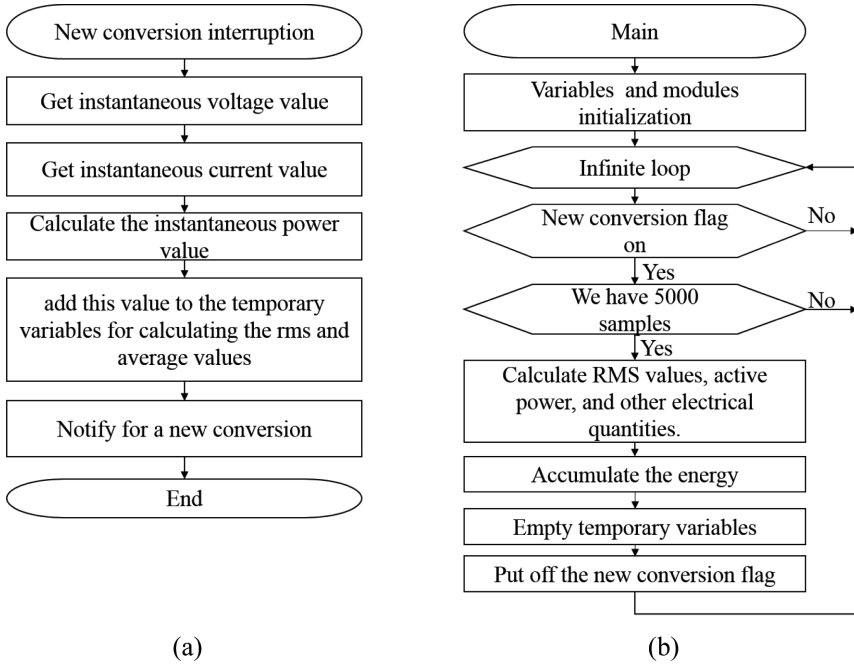

Fig. 7. (a) Flowchart of end of conversion interruption on ADC module. (b) Flowchart of main function including the calculation operation.

The voltage and current chains contain electronic components such as resistors, isolation amplifier, operational amplifier, and ADC. These components could create some measurement errors due to tolerance values, residual ADC offset, amplifiers offset and gain uncertainty. For this reason, the system must be calibrated to eliminate error and consequently to achieve a required accuracy. The calibration process could be performed analogically or numerically. In our case, we choose the numerical methodology to avoid hardware complications. As the measurement chains are linear, to adjust the measurement we have to calibrate the system for just one point of load.

To calibrate the DC offset, we put at the input measurement system a null signal and we measure several values of the instantaneous voltage and the instantaneous current. We note that in this operation the gain variable are initialized to 1. Then we calculate the average value for each chain. After that, we multiply the found values by -1 and store them into the corresponding variables (into V_{DCOFF} variable in Eq. 1 and I_{DCOFF} variable in Eq. 2). We store them into the EEPROM to avoid a system recalibration if the monitoring device is restarted.

For the gain calibration, we apply the reference signal (220 V and 5 A), then we calculate several RMS values of the voltage and the current. After that, we correct the gain value with Eq. 4:

$$G_x = \frac{\text{Reference value}}{\text{The average of the measured values}} \quad (4)$$

where x can be v for the voltage gain or i for the current gain. We store the values of the calculated gains into the corresponding variables as well as into the EEPROM to avoid a system recalibration.

3 Experimental Results and Discussion

3.1 Measurements Accuracy

We have put under evaluation our developed monitoring device to verify the measurement accuracy. We performed the accuracy tests for both RMS voltage and RMS current. For the RMS voltage we tested the accuracy in the interval of [176 V–253 V], because, according to [14], the RMS voltage value can vary between $0.8V_{REF}$ and $1.15V_{REF}$, knowing that the voltage reference value equals 220 V. For the RMS current, we tested the accuracy for the full-scale input range. Both measurement tests are compared with a precision power measurement device. The relative error of measurement is calculated with formula 5:

$$\text{Error}(\%) = \frac{\text{Measured value} - \text{reference value}}{\text{reference value}} \times 100 \quad (5)$$

Figure 8 presents the voltage error of the measurements performed by the developed monitoring device. We notice that the maximum relative error is below 0.2%. Likewise, for the current relative error, seen in Fig. 9, the maximum relative error is below 1% for a RMS current less than 0.5 A, and for the other values this error do not exceed 0.5%.

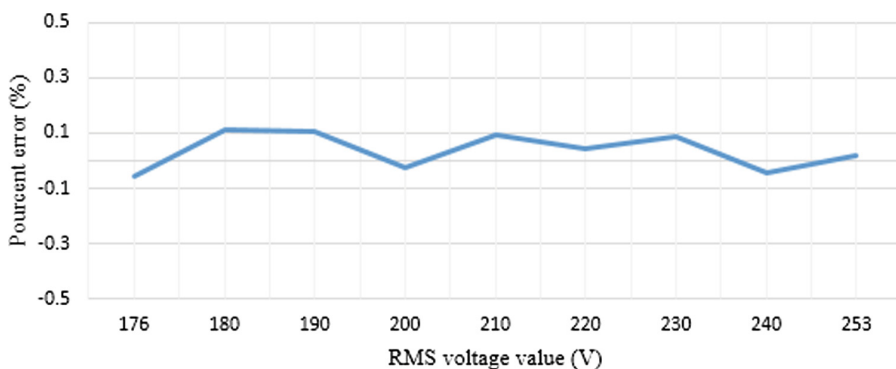

Fig. 8. Voltage variation performance.

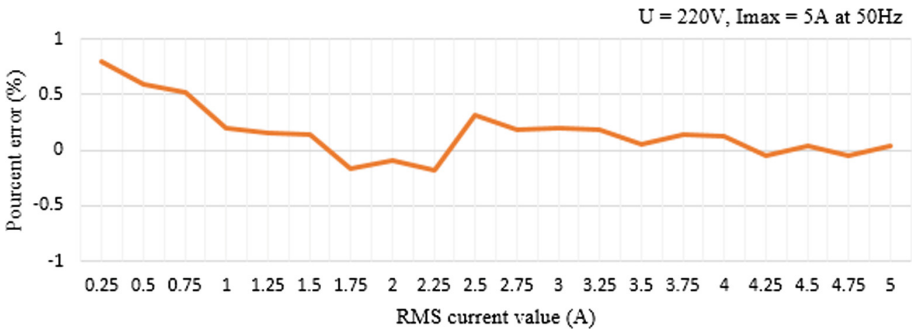

Fig. 9. RMS current performance.

3.2 Data Displaying on the GUI

To monitor and control the household appliances, we developed a GUI (Fig. 10) for the customer. This interface offers the possibility to add a new monitoring device to the monitoring system network, configure edit or delete a device, etc. Furthermore, as presented in Figs. 11 and 12, the user can visualize the power consumption per day, as well as the energy consumption per month and per year. Real time power consumption visualization is also offered (Fig. 13). Moreover, the user has the possibility to import or export data, to activate or disable the monitoring device, to turn on/off the household appliance and to define a turning on/off schedule, as seen in the menu at the left side of the GUI in Figs. 11, 12 and 13.

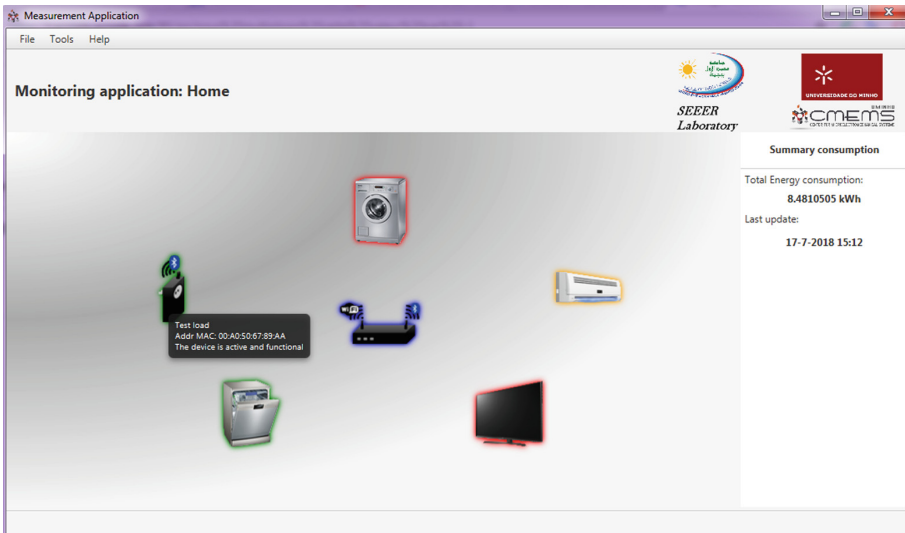

Fig. 10. Home screen of the developed GUI.

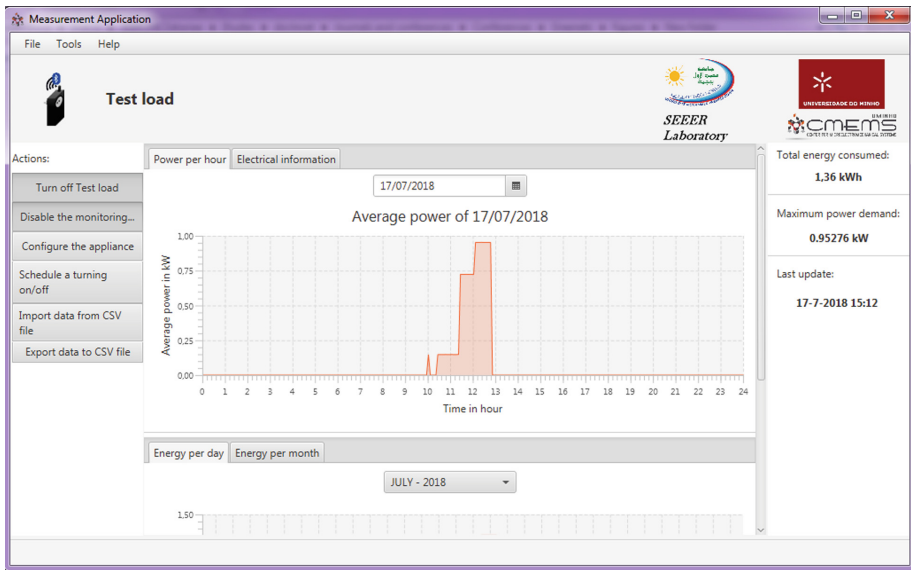

Fig. 11. Average power consumption chart for the test load.

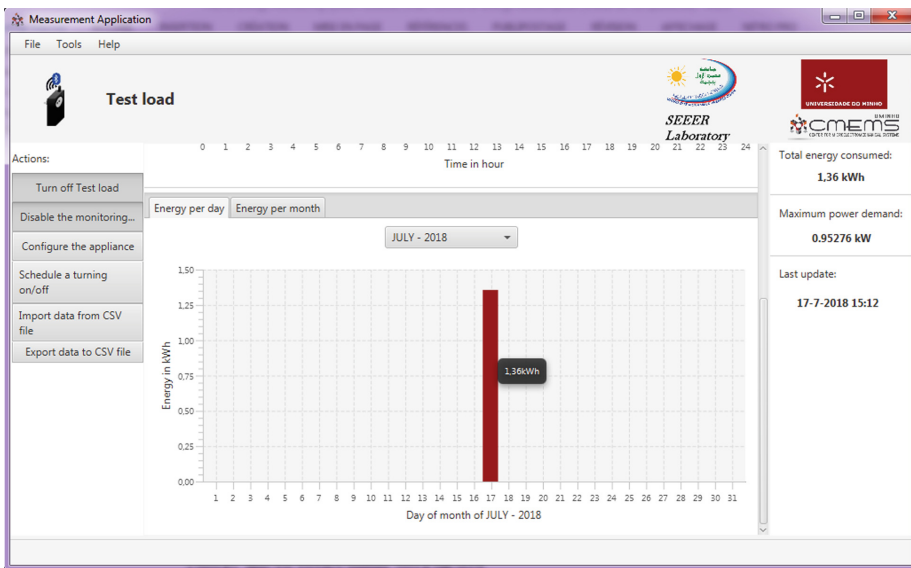

Fig. 12. Energy consumption chart for the test load.

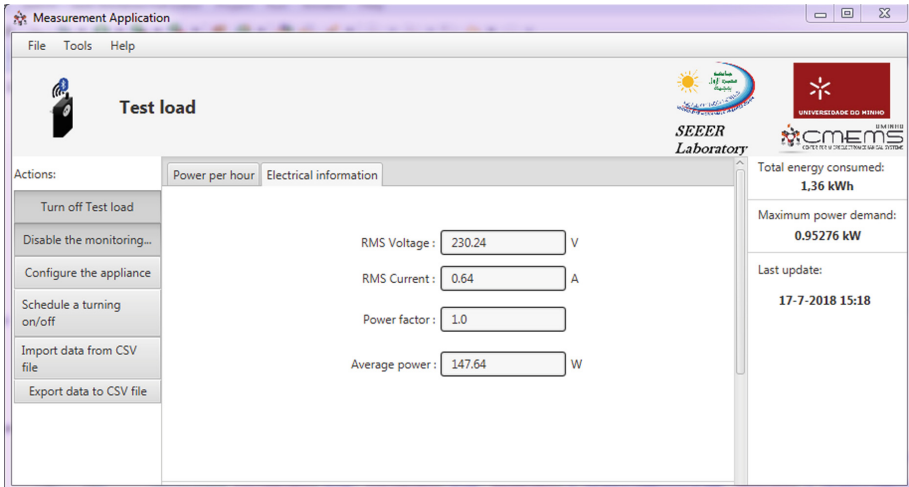

Fig. 13. Real time electrical information tab.

These charts, as well as the electrical information presented, are for a test load of theoretical power equal to 150 W. As shown in Fig. 11, we started tests with this load at 10:25AM. At 11:25AM, we added a second load that consumes 2.5 A. Later, we increased the current consumption until 4.15 A by increasing the second load.

4 Conclusions

The monitoring system proposed in this paper to visualize and control the energy consumption of household appliances forms the basis of the smart home energy management system (SHEMS) that we are developing currently. This system meets the needs of residential consumers to monitor and control household appliances.

This monitoring system is composed by monitoring devices, the gateway (local central device) and the GUI. The monitoring devices are connected to the gateway through a BLE connection. The gateway is responsible for data consumption collection from the monitoring devices, storing this information and making it available to the user. The presented GUI application, which can be installed into a personal computer, connects to the gateway through a Wi-Fi connection using the TCP/IP (Transmission Control Protocol/Internet Protocol) protocols.

The proposed monitoring system was validated through measurement accuracy tests for the developed monitoring device, where we obtained an accuracy below 0.2% for the voltage and below 0.5% for the current. We presented also the developed GUI to monitor and control the household appliances.

As future work, we will implement a home energy management algorithm to manage energy consumption automatically and help the user to control his energy consumption.

Acknowledgments. This work is supported by FCT with the reference project UID/EEA/04436/2013, COMPETE 2020 with the code POCI-01-0145-FEDER-006941.

References

1. Rashed Mohassel, R., Fung, A., Mohammadi, F., Raahemifar, K.: A survey on advanced metering infrastructure. *Int. J. Electr. Power Energy Syst.* **63**, 473–484 (2014)
2. van der Spoel, E., et al.: *New Technologies, Mobility and Security* (2015)
3. Nejat, P., Jomehzadeh, F., Taheri, M., Gohari, M.: A global review of energy consumption, CO₂ emissions and policy in the residential sector (with an overview of the top ten CO₂ emitting countries). *Renew. Sustain. Energy Rev.* **43**, 843–862 (2015)
4. Chupong, C., Plangklang, B.: Electricity bill forecasting application by home energy monitoring system. In: 2017 International Electrical Engineering Congress, iEECON 2017 (2017)
5. Sharma, A., Bhalla, M.: WiFi home energy monitoring system. In: 2016 International Conference on Information Technology - Next Generation, IT Summit, pp. 6–8 (2016)
6. Afonso, J.A., Rodrigues, F., Pereira, P., Gonçalves, H., Afonso, J.L.: Wireless monitoring and management of energy consumption and power quality events. In: *World Congress on Engineering* (2015)
7. Rashdi, A., Malik, R., Rashid, S., Ajmal, A., Sadiq, S.: Remote energy monitoring, profiling and control through GSM network. *Arab. J. Sci. Eng.* **38**, 3249–3257 (2013)
8. Bikrat, Y., Moussaid, D., Benali, A., Benlghazi, A.: Electronic and computer system for monitoring a photovoltaic station. In: *International Conference on Intelligent Systems and Computer Vision (ISCV)*. (2018)
9. Ahsan, U., Bais, A.: Distributed smart home architecture for data handling in smart grid. *Can. J. Electr. Comput. Eng. Can. Genie Electr. Inform.* **41**, 17–27 (2018)
10. Ertugrul, N., McDonald, C.E., Makestas, J.: Home energy management system for demand-based tariff towards smart appliances in smart grids. In: *IEEE 12th International Conference on Power Electronics and Drive Systems (PEDS)*, pp. 511–517 (2017)
11. www.one.org.ma
12. Afonso, J.A., Maio, A.J.F., Simoes, R.: Performance evaluation of bluetooth low energy for high data rate body area networks. *Wirel. Pers. Commun.* **90**, 121–141 (2016)
13. Silva, R.B.C., Afonso, J.A., Afonso, J.L.: Development and test of an intra-vehicular network based on bluetooth low energy. In: *World Congress on Engineering*, pp. 5–9 (2017)
14. ONE-BE: Technical specification - electronics energy meter for low voltage customers (2014)